

Performance Enhancement of Bioinstrumentations in Biomedical Applications

Majid Pouladian,
Leila Karami Gadallo and
Sama Pouladian

Department of Biomedical Engineering,
Islamic Azad University, Tehran, Iran

Corresponding author: Majid Pouladian

✉ pouladian@srbiau.ac.ir

Department of Biomedical Engineering,
Science and Research Branch, Islamic Azad
University, Tehran, Iran.

Tel: 989121390336

Citation: Pouladian M, Gadallo LK, Pouladian S. Performance Enhancement of Bioinstrumentations in Biomedical Applications. Int J Appl Sci Res Rev. 2017, 4:1.

Abstract

In this paper, the role of equipment and devices in medicine as the interface between physician and patient (or sample) is introduced. Role of transducers as sensors or actuators are shown based on two main aims 'diagnosis and therapy'. Some important and informative comments for who wants to design and construct bioinstrumentation amplifiers are mentioned. Two circuitry techniques based on Common Voltage (CV) are introduced. Extracting CV and driving to system's shield instead of grounding could significantly decrease electrical interference from power lines as well as driving a negative voltage to object's body. The performance of differential recording could therefore be enhanced through applying these two techniques and other points mentioned here.

Keywords: Sensor; Actuator; Preamplifier; Bioinstrumentation; Diagnosis; Treatment

Received: January 23, 2017; **Accepted:** May 31, 2017; **Published:** June 08, 2017

Introduction

The ideal aim of all specialists in medical and biological related fields is 'Health Care.' Humans have been generating and applying theoretical and practical tools for Health Care from past to present. Theoretical tools include all hypothesis based formulas, mathematical relations/rules, transformation functions/equations and any data analysis/process method or models. Whilst, physical tools include any gadget from simple instrument like knife and spanner to hi-tech ones like LINAC (Linear Accelerator: High energy electron beam/x-ray generator for cancer treatment) and MRI (Magnetic Resonance Imaging: Hydrogen's proton based system for body tomography).

In medicine, two main aims are 'diagnosis' and 'treatment' of any anatomical/functional abnormality in the human's body. Any abnormal problem (disease/lesion) could be generated from biologic (internal/external) and/or non-biologic sources. Internal biological factors (abnormal cells) could cause genetic disorders such as multiple sclerosis or cancer.

External biologic factors include microorganisms such as viruses, microbes, bacteria, fungi and so on.

Non-biologic sources mean stimulations with so energy levels that vary anatomical/functional normal characteristics of the body. For example, applying hotness/coldness, mechanical force,

acid, radioactive material could cause injury, trauma or lesion on the body's tissues.

From view point of 'cause and effect,' in addition to mentioned causes (known as risk factors), all abnormalities effects including symptoms (sensible only for patients like pain) and signs (observable for physicians) should also be noticed and recorded to diagnose the disease/lesion and then cure the patient by physician.

Since accuracy and precision in diagnostic devices are very important, weak electrical signals recorded by the sensors should be properly manipulated in nowadays noisy environments (with many microwave, electrical and magnetic sources) to achieve high signal to noise ratio.

Therefore, the aim is how we could design bioinstrumentation, particularly a preamplifier with the best performance.

Role of Devices in Medicine

All known 'causes and effects' of any abnormality should be quantified and measured by consistent devices and bioinstrumentations in order to present to physician as shown in D-branch of **Figure 1**.

Based on physician's knowledge and acquired data/info of an abnormal object (i.e., diseased or a sample of patient), physicians

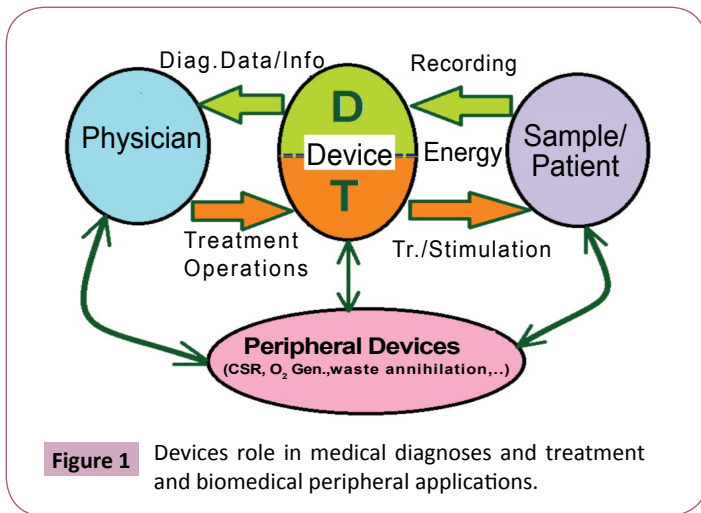

Figure 1 Devices role in medical diagnoses and treatment and biomedical peripheral applications.

diagnose the disease and then order to execute a treatment procedure using therapeutic bioinstrumentations.

Diagnosis could be executed in two methods ‘without stimulation’ (for an ‘active’ object; such as recording function of the object through measuring its infrared, electric, magnetic or acoustic signal) or ‘with stimulation’ (for a ‘passive’ object; such as magnetic, optical, acoustical or electrical impedance measurement).

Generally, it could be said that the diagnostic devices might overcome the limitations of five sensory inputs of physician’s brain (i.e., vision, audition, somatosensory, olfaction and gustation) whilst therapeutic equipment (**Figure 1**) might enhance the performances of motor outputs of physician’s brain. For example, by such devices, physician could see and seek a tumor within the head or body and then manipulate and destroy the cancerous cells without an open surgery.

Some equipment (shown as peripherals in **Figure 1**) are applied not directly for diagnosis or treatment, but used for other purposes such as sterilization, oxygen generation and hospital cultch destroy.

Bioinstrumentations in Health Care

In medical and biological applications, the energy which should be recorded from or entered to the object (via sensor or actuator respectively) has generally so low magnitude that the applied transducers and electronic circuits should have high ‘precision and accuracy’. Any state of such low level energy is named here as ‘parameter,’ for example in temperature control, the parameter is heat. Nowadays, at electronic century (and not optic era yet), for all operations such as transmission, processing and memorizing of data, all kinds of signals should be converted to electrical ones and analysed through bioinstrumentations.

As shown in **Figure 2**, the interface between the object and electronic circuits includes sensor (i.e., parameter to electricity transducer) and actuator (i.e., electricity to parameter transducer).

Transducers (sensors or actuators) should be selected based on the

application and aim and also the amplitude range and frequency band width of such parameter. It’s better that a DC-amplifier (with low gain typically about 20-50) is applied as preamplifier, and required frequency band width provided in Filter block. Two blocks of analog to digital and digital to analog converters (built at one board) are controlled with two parameters number of bits (N-bits for quantizing the voltage values) and sampling frequency (F_s for quantizing the time values that should be greater than double of highest frequency of input analog signal [1]). Any software of signal/data processing techniques is applied through computer’s input/output devices by user (**Figure 2**). Driver block should be used to provide the required power supply of actuator.

Differential technique is necessary in biomedical applications leading to apply instrumentation preamplifiers with two completely similar sensors to eliminate voltages relating to common conditions known as common voltage V_{com} .

Results

In all accurate and precise applications, such as biomedical, clinical and hospital equipment, one could match the function of device with block diagram presented in **Figure 2**.

A practical instrumentation amplifier [1,2] for bio-signal recording could be seen in **Figure 3** with typical values of elements.

One technique known as Guard Drive Output was applied for driving the circuit’s shield [2]. When there is an electric connection between object and sensors (such as EOG, EEG, EMG or ECG recording by electrodes), the technique Reference Drive Output should be used. In this technique, the object is supplied by a negative voltage driver extracted from V_{com} with a serial resistance (R_s) for electrical safety as shown in **Figure 3**.

Some important points in bioinstrumentation design could be written as follows:

1. Two sensors of differential inputs (with three wires) should be identical and similar (in order to common mode rejecting).
2. The positive and negative wires between sensors and preamplifier should be shielded (in coaxial form), as short as possible and in the form of twisted pairs (in order to minimizing electric and magnetic interferences).
3. Connection between sensors and wires should be in the

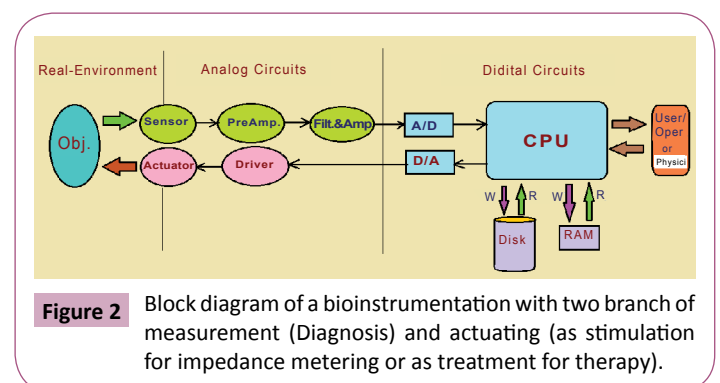
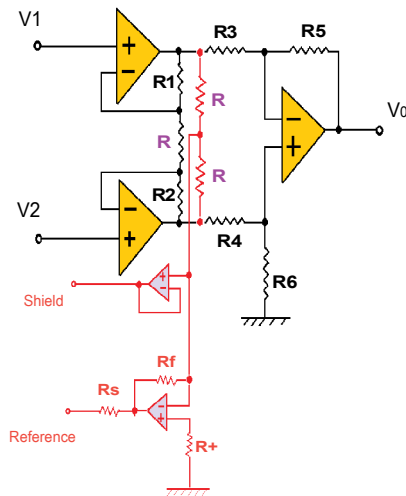

Figure 2 Block diagram of a bioinstrumentation with two branch of measurement (Diagnosis) and actuating (as stimulation for impedance metering or as treatment for therapy).



$$\text{if } R5/R3 = R6/R4 \Rightarrow V_o = \left(\frac{R1 + R2}{R} \right) \left(\frac{-R5}{R3} \right) (V1 - V2)$$

$$R1 = R2 = 35 \text{ K}, R5 = R6 = 9 \text{ K}, R3 = R4 = 1 \text{ K} \Rightarrow V_o / (V2 - V1) = 27$$

$$R_f = 250 \text{ K}, R_s = 20 \text{ K}, R_+ = 630$$

Figure 3 A valid sample of instrumentation amplifier that has been applied and tested for EOG [2] (with electrode reference and shield drivers). It could be used for any weak signal recording (differential) as preamplifier with opAmps ICs (e.g. TL074/84, LF351).

form of sockets (male/female form) and not solder (in order to rejecting thermocouple effect).

4. Instead of grounding the shields of circuits, they attach to V_{com} which could be extracted as shown in **Figure 3** (in order to minimize leakage current between positive/negative wires and their shields leading to decreasing electrical interference from power lines).
5. When the electricity of object (V_{com}) could pass through sensors toward the circuit, Reference Driver Technique could be applied as shown in **Figure 3** (in order to eliminate V_{com} of the object).
6. Pins and screws for installing circuit board on the base or

any other place (e.g. shield or case) near the electronic board should not have ferromagnetic materials such as iron (in order to impede hysteresis phenomenon a nonlinear characteristic).

7. Before digitizing the amplified (analog) signal, it should be passed through a LPF to ensure there is no energy content after cut-off frequency F_c (in order to satisfy Nyquist condition $F_s > 2F_c$ and avoid to occur aliasing [1]).

Discussion

From view point of engineering and bioelectric, clinical devices and bioinstrumentations were introduced structurally and functionally. It was shown that bioinstrumentations could have two parts/branches of "measurement" or acquisition energy from object by sensors and "manipulating" or giving energy to the object by actuators. In order to have a precise and accurate measurement, which properly works, a circuit with operational amplifiers and typical values of resistances (1%) was presented. It is not used capacitors and self-inductances because of rejecting interference by them. Although, instrumentation amplifiers are also constructed in the form of IC's (e.g. AD620), but circuiting by opAmps could have any manipulating and variations abilities. In addition, some significant experimental points in design and construction of a bioinstrumentation were presented here. Electrical safety analysis of such circuits and bioinstrumentations is an important problem that would be discussed in future.

Conclusion

Bioinstrumentations might have manipulation, stimulation or treatment part on the object, in addition to diagnosis (measurement) part. Thus, such devices have both sensors and actuators with their corresponding circuits. Anyhow, presented comments could be useful in practical applications. One could record any biosignal (especially bioelectric signals) by applying the circuit appeared here in **Figure 3**. Electrical safety evaluation and procedures of test and calibration (based on international standards) are important subjects that could be presented in future.

Conflict of Interest

There is no conflict of interests about this paper.

References

- 1 Webster JG (2009) Medical instrumentation application and design (4th edn.). John Wiley and Sons, NJ, USA.
- 2 Pouladian M (1992) EOG recording and processing in order to detect eye position. M.Sc. Dissertation, Sharif University of Technology, Tehran, Iran.