

## **Voltage Source Converters as the building block of HVDC and FACTS Technology in Power Transmission System: A Simulation based Approach**

**T. Navpreet<sup>1</sup>, M. Tarun<sup>1</sup>, B. Amit<sup>1</sup>, J. Kotturu<sup>1</sup>, S. Bhupinder<sup>1</sup>, B. Anant<sup>2</sup> and S. Gurangel<sup>2</sup>**

<sup>1</sup>*Department of Electrical Engg., Lovely Professional University, India.*

<sup>2</sup>*Department of Electronics and Communication Engg., Lovely Professional University, India.*

---

### **ABSTRACT**

*Recent advancement of technology in power electronics, the Voltage Source Converter (VSC) based technology has been selected as the basis for several recent power system projects due to its controllability, compact modular design, ease of system interface and low environmental impact. This paper describes the rationale for selection of VSC technology and the latest technical developments utilized in recent power transmission system. Voltage Source Converters (VSC) have for the first time been used for HVDC transmission in a real network. Experience from the design and commissioning of the transmission shows that the technology has now reached the stage where it is possible to build high voltage converters utilising Insulated Gate Bipolar Transistors (IGBTs). Operation and system tests have proved that the properties that have been discussed for many years regarding VSCs for HVDC are a reality now. They include independent control of active and reactive power, operation against isolated ac networks with no generation of their own, very limited need of filters and no need of transformers for the conversion process. The development of semiconductors and control equipment is presently very rapid and it is evident that this technology will play an important role in the future expansion of electric transmission and distribution system. This paper mainly focus light on- VSC'S based HVDC and FACTS technology.*

**Keywords:** VSC, HVDC, IGBT, Valves, PWM, FACTS, STATCOM, SVC, SSSC, Power Quality issues.

---

### **INTRODUCTION**

Traditional HVDC and FACTS installations have often provided economic solutions for special transmission applications. HVDC is well-suited for long-distance, bulk power transmission, long submarine cable crossings, and asynchronous interconnections. Static var compensators (SVC) provide a reserve source of dynamic reactive power thereby raising power transfer limits. HVDC and FACTS technologies permit transmitting more power over fewer transmission lines. HVDC transmission and reactive power compensation with voltage source converter (VSC) technology has certain attributes which can be beneficial to overall system performance. HVDC Light™ and SVC Light™ technology developed by ABB employs voltage source converters (VSC) with series-connected IGBT (insulated gate bipolar transistor) valves controlled with pulse width modulation (PWM). VSC converters used for power transmission (overvoltage support combined with an energy storage source) permit continuous and independent control of real and reactive power. Reactive power control is also independent of that at any other terminal. Reactive power control can be used for dynamic voltage regulation to support the interconnecting ac system following contingencies. This capability can increase the overall transfer levels. Forced commutation with VSC even permits black start, i.e., the converter can be used to synthesize a balanced set of three phase voltages much like a synchronous machine. On March 10, 1997 power was transmitted on the world's first HVDC transmission with VSC converters between Hellsjön (Hn) and Grängesberg (Gbrg) in central Sweden. Since then extensive testing has been performed in order to prove that the Voltage Source HVDC technology fulfils the expectations that since long time have been expressed in different publications.

### Voltage Source Converter(VSC) [2]

Basically a voltage-sourced converter generates ac voltage from a dc voltage. It is for historical reasons, often referred to as an inverter, even though it has the capability to transfer power in either direction. With a voltage source converter, the magnitude, the phase angle and the frequency of the output voltage can be controlled. In these converters the dc side voltage always has one polarity, and the power reversal takes place through reversal of dc current polarity. On dc side the voltage is supported by a capacitor. This capacitor is large enough to at least handle a sustained charge/discharge current that accompanies the switching sequence of the converter valves and shifts in phase angle of the switching valves without significant change in the dc voltage. For the purpose of discussion in this paper, the dc capacitor voltage will be assumed constant. On the other hand the ac side is the generated ac voltage connected to the ac system via an inductor.

### VSC based HVDC Transmission System

#### Concept of HVDC

With the advent, of thyristors valve converters HVDC transmission became more attractive. The first HVDC system using thyristors valves was the eel river scheme commissioned in 1972, forming a 320 mw back to back dc interconnection between the power systems of the Canadian provinces of new Brunswick and quebec. Thyristors valves have now become standard equipment for dc converter stations. Recent developments in conversion equipment have reduced their size and cost and improved their reliability.

Main types of applications for which VSC based HVDC has been used-

1. Underwater cables longer than about 30 km. Ac transmission is impractical for such distances because of the cable requiring intermediate compensation systems.
2. Asynchronous link between two ac systems.
3. HVDC transmission is a competitive alternative to ac transmission for distances in excess of about 600 km. VSC have been made possible that the HVDC systems have ability to rapidly control the transmitted power.

HVDC transmission system based on Voltage Source Converters (VSCs) has taken on some excellent advantages. The new VSC-HVDC system known as "HVDC Light" or "HVDC Plus" [16,17] by leading vendors, has been applied in several special occasions such as the connection of off-shore wind farms or oil drilling platforms into the mainland electrical network and for underground transmission or distribution systems within congested cities. The differences in structure between the two types of converters (Conventional HVDC and VSC-HVDC) contribute to the differences in their performance. Generally, the new transmission technology has the following advantages compared with conventional, thyristor based HVDC [18-20]:

- Possibility to control the reactive power (consumed or generated by the converter) independently of the active power (to or from the converter).
- No risk of commutation failures in the converter.
- Ability to connect to weak AC networks, or even dead networks.
- Faster response due to increased switching frequency (PWM).
- Minimal environmental impact.

However, VSC transmission does have some disadvantages, which include potentially high power losses and high capital costs when compared with conventional HVDC, but the technology continues to evolve. This paper presents the elements of VSC-HVDC which uses twelve pulse three level converter topology and its control design.

#### Fundamentals of VSC transmission

The fundamentals of VSC transmission operation may be explained by considering each terminal as a voltage source connected to the AC transmission network via a three-phase reactor. The two terminals are interconnected by a DC link, as schematically shown in Fig. 3.1

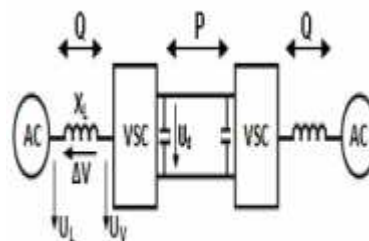

Fig.3.1 Basic VSC transmission

Fig.3. 2 shows a phasor diagram for the VSC converter connected to an AC network via a transformer inductance. The fundamental voltage on the valve side of the converter transformer, i.e.  $UV(I)$ , is proportional to the DC voltage as been expressed in Eq(1):

$$UV(I) = kuUd \tag{1}$$

The quantity  $ku$  can be controlled by applying additional number of commutation per cycle, i.e. applying pulse with modulation (PWM). Using the definition of the apparent power and neglecting the resistance of the transformer results in the following equations for the active and reactive power:

$$P = U_d \cdot I_d = \frac{U_L \cdot U_{V(I)} \sin \delta}{X_L} \tag{2}$$

$$Q = \frac{U_L \cdot (U_L - U_{V(I)} \cdot \cos \delta)}{X_L} \tag{3}$$

The active and reactive power will in the following be defined as positive if the powers flow from the AC network to the converter. The phase displacement angle  $\delta$  will then be positive if the converter output voltage lags behind the AC voltage in phase.

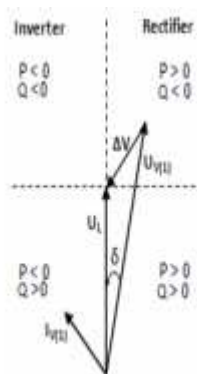

Fig 32 Phasor diagram of VSC and direction of power flows

Equation (2) gives that the active power is proportional to the DC current and the DC voltage. Furthermore it is mainly determined by the phase-displacement angle  $\delta$ . A positive phase-shift results in that the active power flows from the AC network to the converter. However the reactive power is mainly determined by the difference between the magnitudes of the AC bus voltage and the converter output voltage according to the Eq.(3). The reactive power is fed from the voltage with higher magnitude towards the voltage with the lower magnitude. These features permit the independent control of the reactive and active power which is a major advantage for the VSC. P-Q diagram is a circle according to Eq.(4) with the centre not located at origin as it does for the line commutated converters as shown in Fig. 3.3.

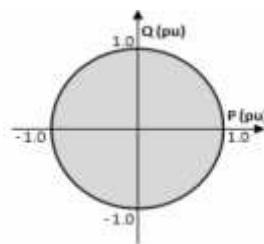

Fig 33 P-Q characteristics of a VSC-HVDC system

$$P^2 + \left( Q - \frac{U_L^2}{X_L} \right)^2 = \left( \frac{U_L \cdot U_{V(I)}}{X_L} \right)^2 \tag{4}$$

If the output voltage of the converter  $UV(I)$  is reduced, i.e. by using PWM, supply of any active and reactive power within the circle is possible.

### 3.3 VSC-HVDC Control strategy

Fig.3.4 shows an overview diagram of the VSC control system and its interface with the main circuit [6]. The converter 1 and converter 2 controller designs are identical. The two controllers are independent with no communication between them. Each converter has two degrees of freedom. In our case, these are used to control:

- $P$  and  $Q$  in station 1 (rectifier)
- $Ud$  and  $Q$  in station 2 (inverter).

**Phase locked loop**

The phase locked loop (PLL) shown in fig3.4 is used to synchronise the converter control with the line voltage and also to compute the transformation angle used in the *d-q* transformation. The PLL block measures the system frequency and provides the phase synchronous angle  $\theta$  for the *d-q* transformations block. In steady state,  $\sin(\theta)$  is in phase with the fundamental (positive sequence) of *a* component and phase A of the point of common coupling voltage (*Uabc*).

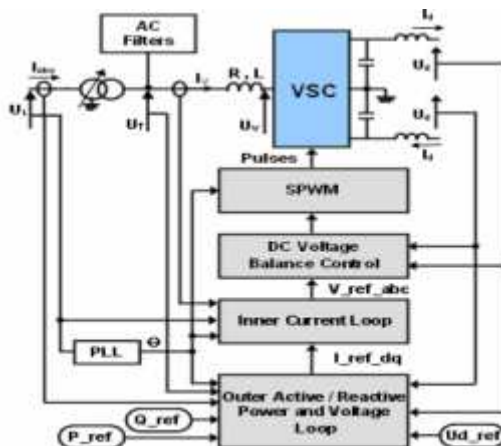

Fig.54 Overview diagram of the VSC control system

**Outer active and reactive power and voltage loop**

The active power or the DC voltage is controlled by the control of  $\delta$  and the reactive power is controlled by the control of the modulation index (*m*). The instantaneous real and imaginary power of the inverter on the valve side can be expressed in terms of the *dq* component of the current and the voltage on the valve side as follows:

$$p = \frac{3}{2} \cdot \text{Re}(\bar{u}_f^{dq} \cdot \bar{i}_v^{*dq}) = \frac{3}{2} \cdot (u_{fd} \cdot i_{vd} + u_{fq} \cdot i_{vq}) \tag{5}$$

$$q = \frac{3}{2} \cdot \text{Im}(\bar{u}_f^{dq} \cdot \bar{i}_v^{*dq}) = \frac{3}{2} \cdot (-u_{fd} \cdot i_{vq} + u_{fq} \cdot i_{vd}) \tag{6}$$

If the reference of the *dq*-frame is selected such that the quadrature component of the voltage is being very small and negligible ( $uLq \approx 0$ ) then the Eq(5) and Eq(6) indicate that the active and the reactive power are proportional to the *d* and *q* component of the current respectively. Accordingly, it is possible to control the active power (or the DC voltage or the DC current) and the reactive power (or the AC bus voltage) by control of the current components *ivd* and *ivq* respectively. The active and reactive power and voltage loop contains the outer loop regulators that calculate the reference value of the converter current vector ( $I^{*dq}$ ) which is the input to the inner current loop.

**Inner Current Loop**

For each of the phases we can write:

$$u_f - u_v = L \frac{di_v}{dt} + R \cdot i_v \tag{7}$$

**Characteristic of VSC used in HVDC and FACTS system**

The major element of the converter are the valve bridge and converter transformer. The valve bridge is an array of high voltage switches or valves that sequentially connect the three phase alternating voltage to the dc terminals so that the desired conversion and control of power are achieved. The converter transformer provides the appropriate interface between the ac and dc systems. In this we will describe the structure and operation of practical converter circuit used in HVDC system.

### Valve characteristics

The early HVDC systems used mercury arc valves. Mercury arc valves with rated currents of the order of 1000 to 2000 A and rated peak inverse voltage of 50 to 150 KV have been built and used. The disadvantages of mercury arc valves are their large size and tendency to conduct in reverse direction.

All HVDC system built since the mid- 1970 have used thyristors valves. Thyristors valves rated at 2500 to 3000 A and 3 to 5 KV have been developed. The thyristor valve will conduct only when the anode is positive with respect to cathode and when there is positive voltage applied to the gate. Conventional thyristor device has only the turn on control; its turn off depends on the current coming to zero as per circuit and system conditions. Device such as gate turn off thyristor( GTO), integrated gate bipolar transistor(IGBT), MOS turn off thyristor (MTO) and integrated gate- commutated thyristors(IGCT) have turn on and turn off capability. These devices referred to as turn off devices are more expensive and have higher losses than the thyristors without turn off capability; however turn off devices enable voltage source converter concepts that can have significant overall system cost and performance advantages. These valves made converter self commutating as against the conventional line commutating converters.

Converters applicable to recent HVDC and FACTS technology would be of the self commutating type.

Since the direct current in a voltage sourced converter flows in either direction, the converter valves have to be bidirectional and also the dc voltage does not reverse, the turn off devices need not have reverse voltage capability, such turn off devices known as asymmetric turn off devices. Thus a voltage- sourced converter valve is made up of an asymmetric turn off device such as GTO with a parallel diode connected in reverse. Some turn off devices such as the IGBTs and IGCTs, may have a parallel reverse diode built in as part of a complete integrated device suitable for VSCs. In reality, there would be several turn off device diode units in series for high voltage applications. In general , the symbol of one turn off device with one parallel diode as shown in Fig 4.1 represent a valve of appropriate current and voltage rating required for the converter.

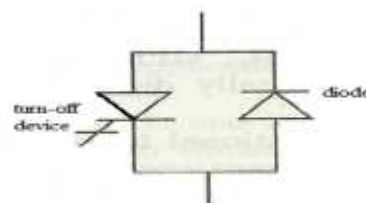

fig 4.1 valve for a voltage sourced converter

### Three phase full wave bridge voltage sourced converter (6-pulse VSC)

#### Converter operation

Fig 4.2(a) shows a three phase, full-wave converter with six valves ,(1-1') to (6-6').It consist of three phase-legs, which operate in concert,120 degrees apart. The three phase-legs operate in a square wave mode. Each valve alternately closes for 180 degrees as shown by the waveforms  $v_a$  ,  $v_b$ , and  $v_c$  in fig 4.2(b).These three square-wave waveforms are the voltages of ac buses a, b, and c with respect to a hypothetical dc -capacitor midpoint N, with peak voltages of  $+V_d/2$  and  $-V_d/2$ . The three phase legs have their timing 120 degrees apart with respect to each other in what amounts to a 6-pulse converter operation.

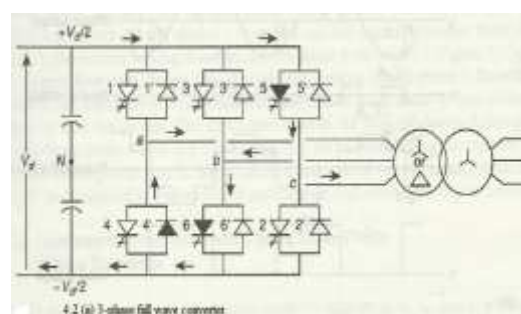
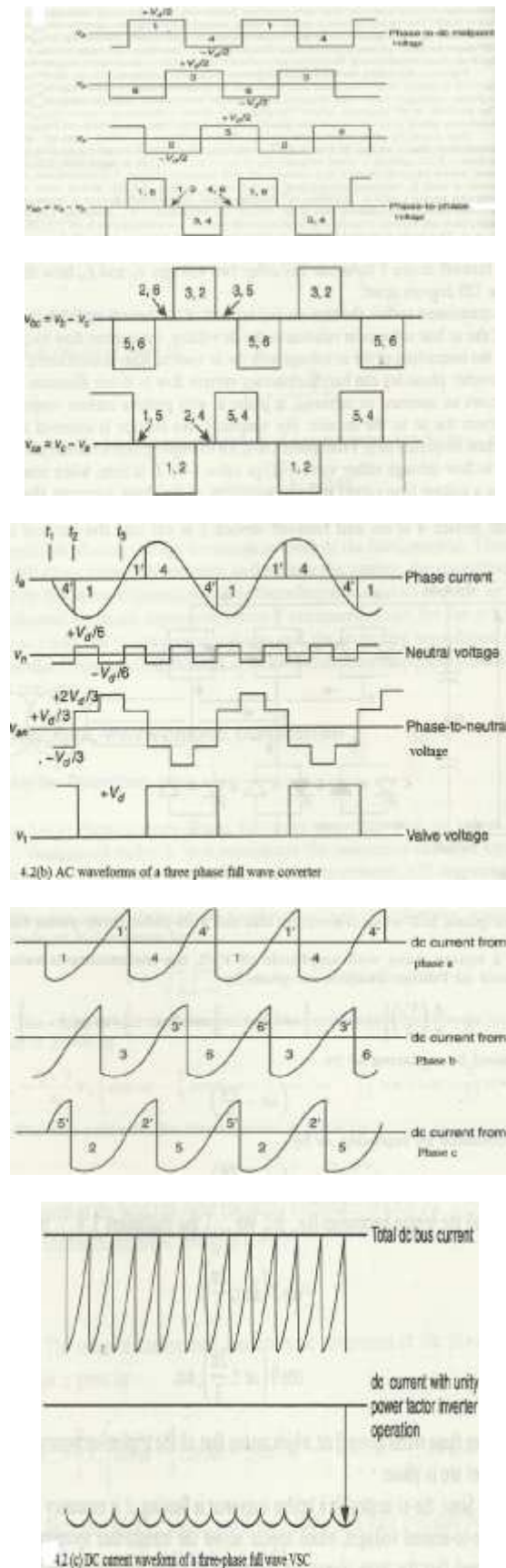

Fig 4.2(b) shows the three phase- to- phase voltages  $v_{ab}$  ,  $v_{bc}$  , and  $v_{ca}$  .The turn-on and turn-off of the devices establish the waveforms of the ac bus voltages in relation to the dc voltage, the current flow itself is the result of the interaction of the ac voltage with the ac system .Each converter phase-leg can handle resultant current flow in either direction .Fig(4.2b) shows an assumed ac current  $i_a$  in phase a, with positive current representing current from the ac to the dc side.



From point  $t_1$  to  $t_2$ , for example, phase a current is negative and has to flow either valve 1-1' or valve 4-4'. It is seen ,when comparing the phase a voltage with the waveform of the phase a current, that when turn-off device 4 is on

turn-off device 1 is off and the current is negative, the current would actually flow through diode 4'. But later, say from point  $t_2$  to  $t_3$ , when device 4 is turned off and device 1 is turned on, the negative current flows through device 1, the current having transferred from diode 4' to device 1.

In fact at any time, three valves are conducting in a three-phase converter system and only the active power part of the ac current and part of the harmonics flows in to the dc side as shown in fig 4.2(c).

### 12-pulse, 24-pulse and 48-pulse operation of VSCs

In the arrangement of Fig 4.3(a), the two six-pulse converters, involving a total of six phase-legs are connected in parallel on the same dc bus, and work together as a 12-pulse converter. It is necessary to have two separate transformers, otherwise phase shift in the non-12-pulse harmonics i.e. 5<sup>th</sup>, 7<sup>th</sup>, 17<sup>th</sup>, 19<sup>th</sup>, in the secondaries will result in a large circulating current due to common core flux. Therefore, it is necessary to connect the transformer primaries of two separate transformer in series and connect the combination to the ac bus. With this arrangement the two waveforms  $v_{an}$  and  $v_{ab}$  adjusted for the transformer ratio and one of them displaced by 30 degrees when added will give a third waveform, which is seen to be a 12-pulse waveform, closer to being a sine wave than each of the six-pulse waveform as shown in fig 4.3(b). The two converters can also be connected in series on the dc side for a 12-pulse converter of twice the dc voltage, figure 4.3(c). In such a case, it is important to provide a control to ensure that the two dc buses (capacitors) have equal voltages.

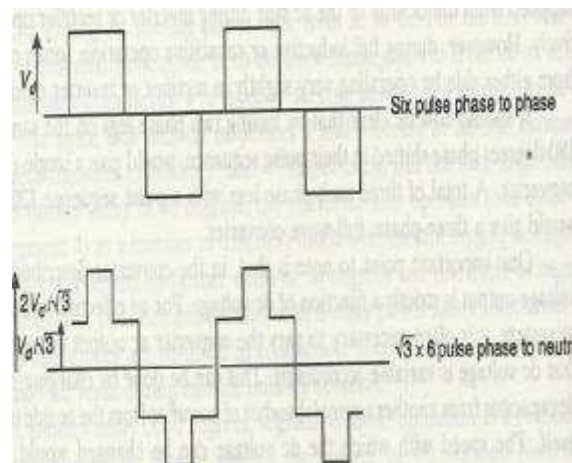
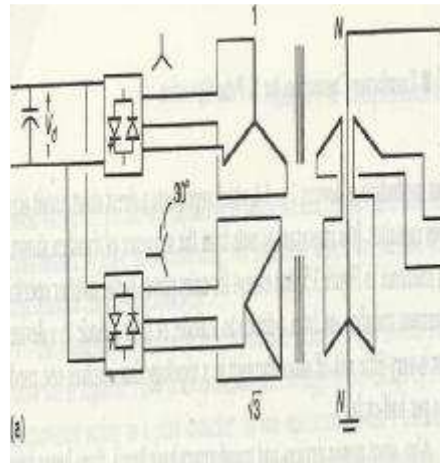

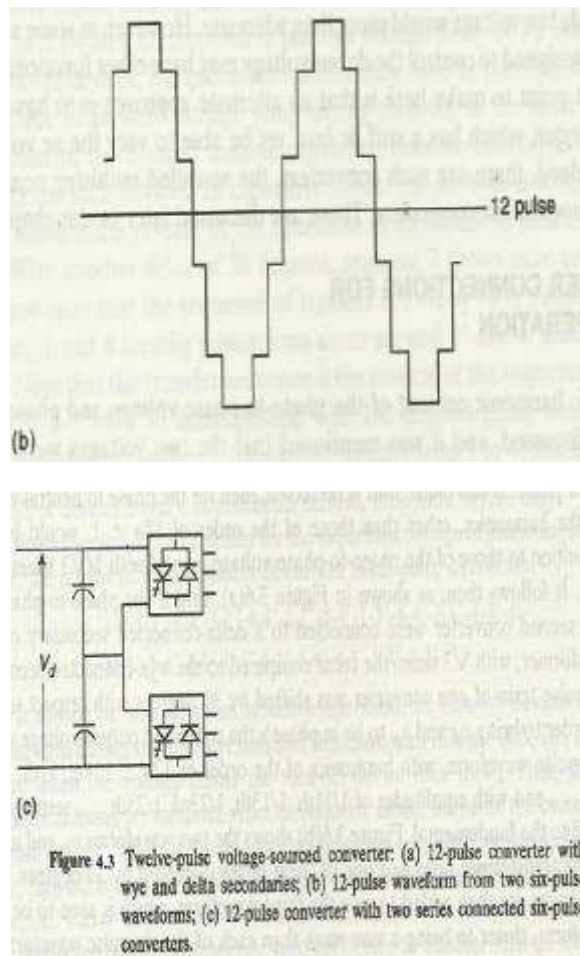

Two 12-pulse converters, phase shifted by 15 degrees from each other, can provide a 24-pulse converter, obviously with much lower harmonics on ac and dc side. 15 degrees phase shift can be arranged by two approaches-

1. To provide 15 degrees phase-shift windings on the two transformers of one of the two 12-pulse converters.
2. To provide phase-shift windings for +7.5 degrees phase shift on the two transformers of one 12-pulse converter and -7.5 degrees on the two transformers of the other 12-pulse converter shown in fig 4.4(a).

The 2<sup>nd</sup> approach is preferred because it requires transformers of the same design and leakage inductances. Primaries of all four transformers can be connected in series as shown in fig 4.4(b) in order to avoid harmonic circulation current corresponding the 12-pulse order, i.e., 11<sup>th</sup>, 13<sup>th</sup>, 23<sup>th</sup>, 24<sup>th</sup>.

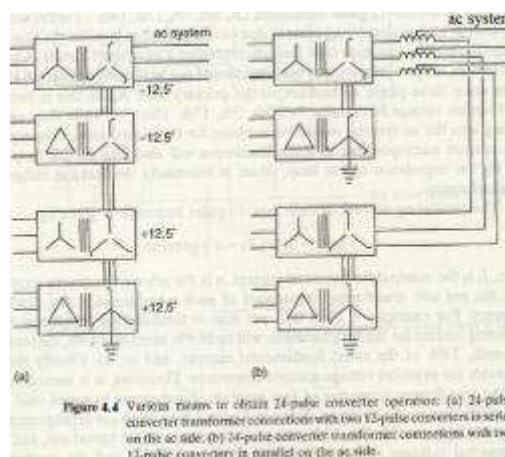



For high power FACTS controllers and HVDC converters, from the point of view of the ac system, even a 24-pulse converter without ac filters could have voltage harmonics, which are higher than acceptable level. The alternative, is to go to 48-pulse operation with 8 six-pulse groups, with one set transformers of one 24-pulse converter phase shifted from the other by 7.5 degrees ,or one set shifted by +3.75 degrees and the other by -3.75 degrees. With 48-pulse operation, ac filters should not be necessary.

**Three level voltage-sourced converter**

*Operation of three level converter*

As we that it would be desirable to vary the magnitude of ac output voltage without having to change the magnitude of the dc voltage. The concept of three level converter accomplish that to some extent. One phase- leg of a three level converter is shown in figure 4.5(a). The other two phase legs would be connected across the same dc bus-bars and the clamping diodes connected to the same midpoint N of the dc capacitor .It is seen that each half of the phase leg is split in to two series connected valves, i.e., 1-1' is split in to 1-1' and 1A-1A'.The midpoint of the split valves is connected by diodes and D<sub>4</sub> to the midpoint N. However ,doubling the number of valves with the same voltage rating would double the dc voltage and hence the power capacity of the converter .Fig 4.5(b) shows output voltage corresponding to one three level phase leg. With three level converter we can observed that for the duration of zero output voltage , the phase-leg current flows in to the midpoint of the two capacitors and thus flow through the dc capacitor. This current is mainly of third harmonic and it is independent of the converter pulse number.

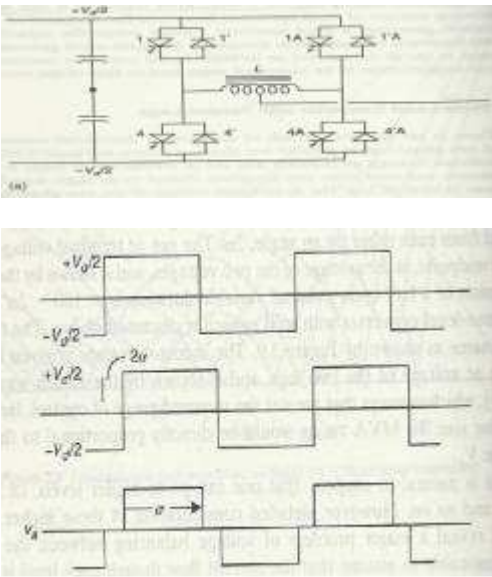
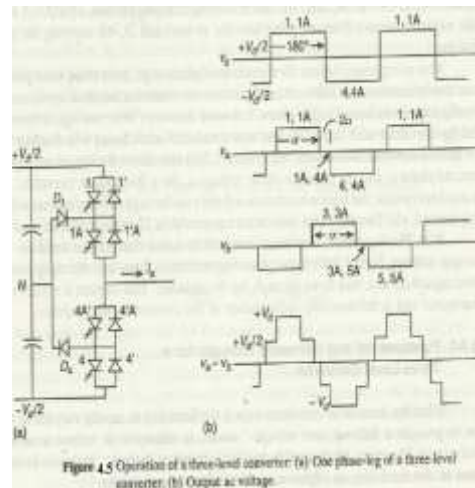

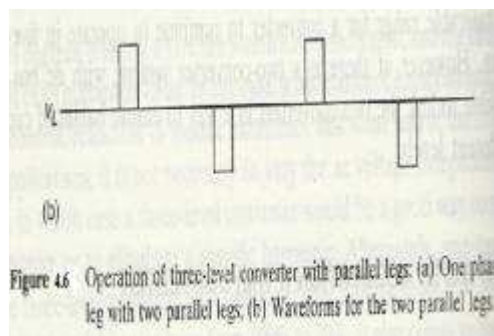

*Three-level converter with parallel legs*

In this arrangement we connect two phase-legs in parallel per phase as shown in fig. 4.6(a). The two legs are paralleled through an inductor and the ac connection is made at the midpoint of this inductor, and their pulse sets are shifted by an angle  $\alpha$  each in the opposite directions. The ac terminal voltage of the two phase legs, with respect to a hypothetical dc midpoint are shown in fig. 4.6(b)

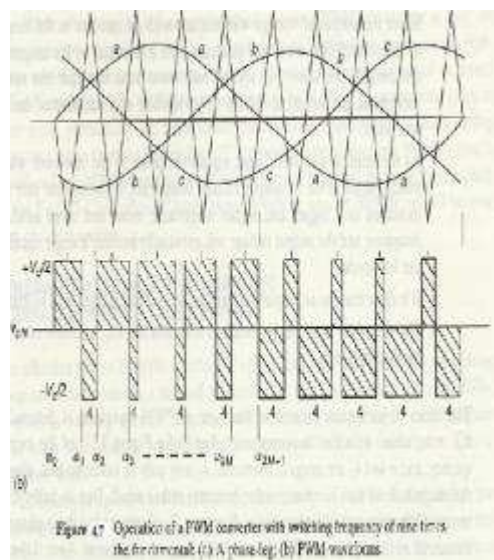
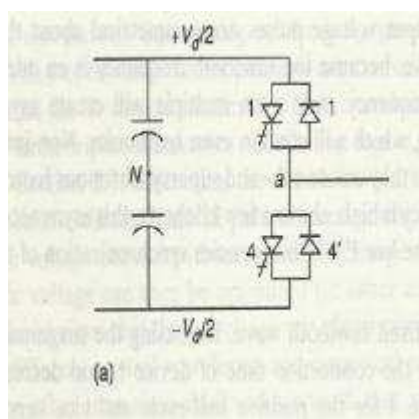

**VSC technology and pulse width modulation (PWM)**

HVDC was originally developed from technologies used in industrial drive systems. There the PCC (Phase Commutated Converter) technology which is at present being used for HVDC has now almost entirely been replaced by VSC technology. The fundamental difference between these two technologies is that VSCs need components that can turn-off the current and not only turn it on as is the case with PCCs. Since in a VSC the current can be turned off, there is no need for a network to commute against. In HVDC-applications it could then be advantageous to use the VSC technology especially to supply passive load networks, that is areas which lack rotating machines or which

do not have enough power in the rotating machines (short circuit power too low). With the appearance of high switching frequency components, such as IGBTs it becomes advantageous to use Pulse Width Modulation (PWM) Technology. In a VSC converter the ac. voltage is created by switching very fast between two fixed voltages. The desired fundamental frequency voltage is created through low pass filtering of the high frequency pulse modulated voltage as shown in fig 4.7(a) and(b).

With PWM it is possible to create any phase angle or amplitude (up to a certain limit) by changing the PWM pattern, which can be done almost instantaneously. Hereby, PWM offers the possibility to control both active and reactive power independently of each other. This makes the Pulse Width Modulated Voltage Source Converter a close to ideal component in the transmission network. From a system point of view it acts as a motor or generator without mass that can control active and reactive power almost instantaneously. Furthermore, it does not contribute to the short-circuit power since the ac. current can be controlled.

## 5. VSC based flexible Ac transmission system (FACTS) technology

### 5.1 FLEXIBLE AC TRANSMISSION SYSTEMS (FACTS)

The rapid development of power electronics technology provides exciting opportunities to develop new power system equipment for better utilization of existing system. Since 1990, a number of control devices under the term FACTS technology have been proposed and implemented. FACTS devices can be effectively used for power flow control, load sharing among parallel corridors, voltage regulation, enhancement of transient stability and mitigation of system oscillations. By giving additional flexibility, FACTS controllers enable a line to carry power closer to its thermal rating. Mechanical switching has to be supplemented by rapid response power electronics. It may be noted that FACTS is an enabling technology, and not a one-on-one substitute for mechanical switches.

FACTS employ high speed thyristors for switching in or out transmission line components such as capacitors, reactors or phase shifting transformer for some desirable performance of the systems. The FACTS technology is not a single high-power controller, but rather a collection of controllers, which can be applied individually or in coordination with others to control one or more of the system parameters.

### 5.2 PRINCIPLE AND OPERATION OF VSC in FACTS

Controllable reactive power can be generated by dc to ac switching converters which are switched in synchronism with the line voltage with which the reactive power is exchanged. A switching power converter consists of an array of solid state switches which connect the input terminals to the output terminals. It has no internal storage and so the instantaneous input and output power are equal. Further the input and output terminations are complementary, that is, if the input is terminated by a voltage source (charged capacitor or battery), output is a current source (which means a voltage source having an inductive impedance) and vice versa. Thus, the converter can be voltage sourced (shunted by a capacitor or battery) or current sourced (shunted by an inductor). Single line diagram of the basic voltage sourced converter scheme for reactive power generation is drawn in Fig. 5.1. For reactive power flow bus voltage  $V$  and converter terminal voltage  $V_0$  are in phase.

Then on per phase basis

$$I = \frac{V - V_0}{X}$$

The reactive power exchange is

$$Q = VI = \frac{V(V - V_0)}{X}$$

The switching circuit is capable of adjusting  $V_0$ , the output voltage of the converter. For  $V_0 < V$ ,  $I$  lags  $V$  and  $Q$  drawn from the bus is inductive, while for  $V_0 > V$ ,  $I$  leads  $V$  and  $Q$  drawn from the bus is leading. Reactive power drawn can be easily and smoothly varied by adjusting  $V_0$  by changing the on time of the solid-state switches. It is to be noted that transformer leakage reactance is quite small (0.1-0.15 pu), which means that a small difference of voltage ( $V - V_0$ ) causes the required,  $I$  and  $Q$  flow. Thus the converter acts like a static synchronous condenser (or VAR generator). A typical converter circuit is shown in Fig. 5.2. It is a 3-phase two-level, six-pulse H-bridge with a diode in anti-parallel to each of the six thyristors (Normally, GTO's are used). Timings of the triggering pulses are in synchronism with the bus voltage waves.

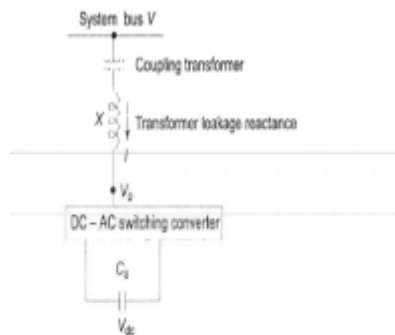

Fig. 5.1 Static reactive power generator

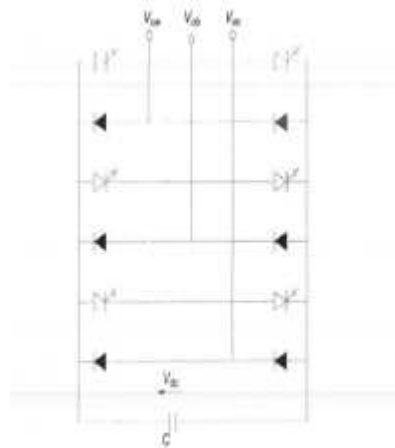

Fig. 5.2 Three-phase, two-level six-pulse bridge

As the converter draws only reactive power, real power drawn from the capacitor is zero. Also at dc (zero frequency) the capacitor does not supply any reactive power. Therefore, the capacitor voltage does not change and the capacitor establishes only a voltage level for the converter. The switching causes the converter to interconnect the 3-phase lines so that reactive current can flow between them. The converter draws a small amount of real power to provide for the internal loss (in switching). If it is required to feed real power to the bus, the capacitor is replaced by a storage battery. For this the circuit switching has to be modified to create a phase difference  $\delta$  between  $V_0$  and  $V$  with  $V_0$  leading  $V$ . The above explained converter is connected in shunt with the line. On similar lines a converter can be constructed with its terminals in series with the line. It has to carry the line current and provide a suitable magnitude (may also be phase) voltage in series with the line. In such a connection it would act as an impedance modifier of the line.

### FACTS CONTROLLERS

The development of FACTS controllers has followed two different approaches. The first approach employs reactive impedances or a tap changing transformer with thyristor switches as controlled elements, the second approach employs self-commutated static converters as controlled voltage sources. In general, FACTS controllers can be divided into four categories.

(i) series (ii) shunt (iii) combined series-series (iv) combined series-shunt controllers.

The general symbol for a FACTS controller is given in Fig. 5.3(a). Which shows a thyristor arrow inside a box. The series controller of Fig. 5.3(b) could be a variable-impedance, such as capacitor, reactor, etc. or a power electronics based variable source. All series controllers inject voltage in series with the line. If the voltage is in phase quadrature with the line, the series controller only supplies or consumes variable reactive power. Any other phase relationship will involve real power also.

The shunt controllers of Fig. 5.3(c) may be variable impedance, variable source or a combination of these. All shunt controllers inject current into the system at the point of connection. Combined series-series controllers of Fig. 5.3(d) could be a combination of separate series controllers which are controlled in a coordinated manner or it could be a unified controller.

Combined series-shunt controllers are either controlled in a coordinated manner as in Fig. 5.3(e) or a unified Power Flow Controller with series and shunt elements as in Fig. 5.3(f). For unified controller, there can be a real power

exchange between the series and shunt controllers via the dc power link. Storage sources such as a capacitor, battery, superconducting magnet, or any other source of energy can be added in parallel through an electronic interface to replenish the converter's dc storage as shown dotted in Fig. 5.3 (b). A controller with storage is more effective for controlling the system dynamics than the corresponding controller without storage. The group of FACTS controllers employing VSC based synchronous voltage sources-

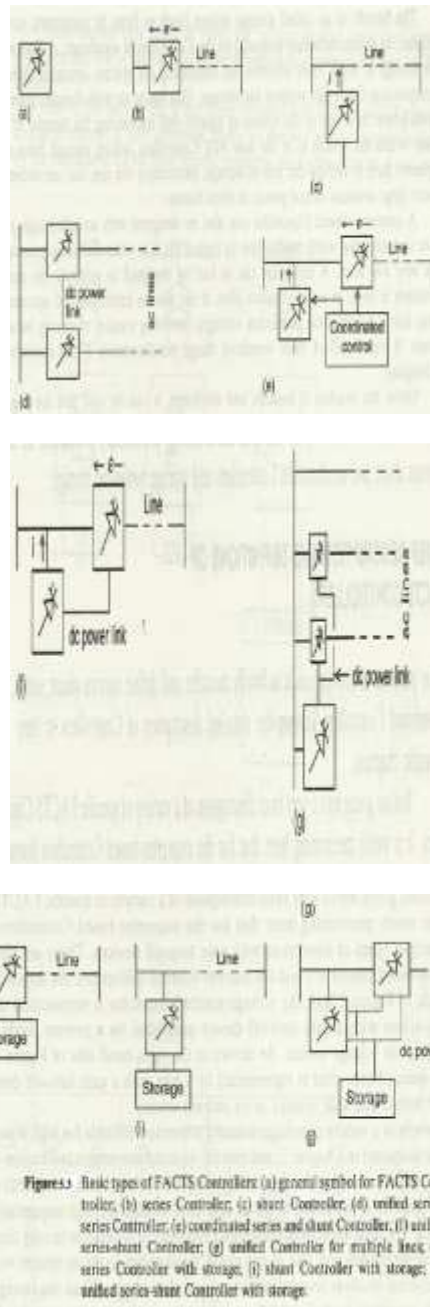

**STATCOM**

STATCOM is a static synchronous generator operated as a shunt-connected static VAR compensator whose capacitive or inductive output current can be controlled independent of the ac system voltage. The STATCOM, like its conventional counterpart, the SVC, controls transmission voltage by reactive shunt compensation. It can be based on a voltage-sourced or current-sourced converter. Figure 5.4(a) shows a one-line diagram of STATCOM based on a voltage-source and a current source dc converter. Normally a voltage-sourced converter is preferred for most converter-based FACTS controllers.

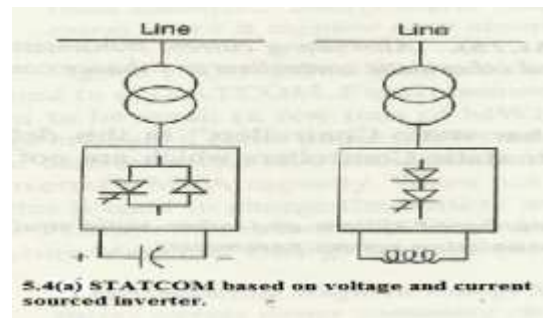

STATCOM can be designed to be an active filter to absorb system harmonics. A combination of STATCOM and any energy source to supply or absorb power is called static synchronous generator (SSG) as shown in fig 5.4(b). Energy source may be a battery, flywheel, superconducting magnet, large dc storage capacitor, another rectifier/inverter etc.

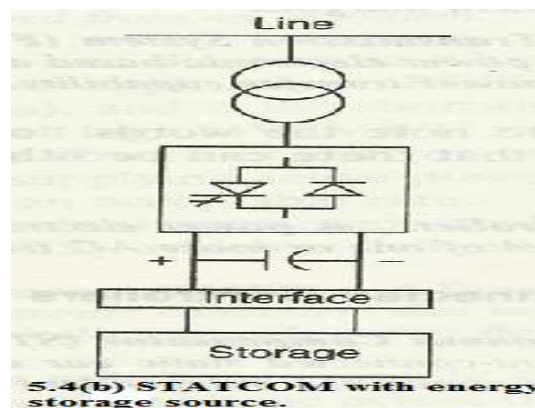

#### Static Synchronous Series Compensator (SSCC)

It is a series connected controller. Though it is like STATCOM, but (its output voltage is in series with the line. It thus controls the voltage across the line and hence its impedance.

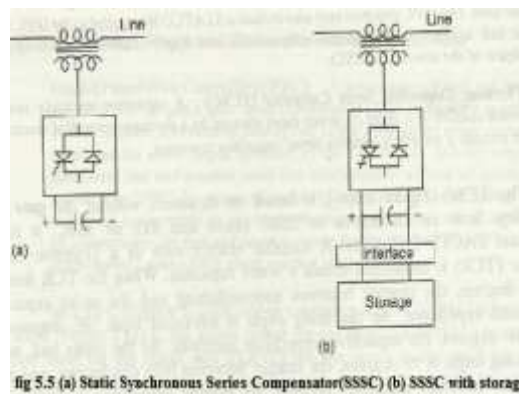

#### Interline Power Flow Controller (IPFC)

This is a recently introduced controller [2,3]. It is a combination of two or more static synchronous series compensators which are coupled via a common dc link to facilitate bi-directional flow of real power between the ac terminals of the SSSCs, and are controlled to provide independent reactive series compensation for the control of real power flow in each line and maintain the desired distribution of reactive power flow among the lines. Thus it manages a comprehensive overall real and reactive power management for a multi-line transmission system.

#### Unified Power Flow Controller (UPFC)

This controller is connected as shown in Fig. 5.6. It is a combination of STATCOM and SSSC which are coupled via a common dc-link to allow bi-directional flow of real power between the series output terminals of the SSSC and the shunt output terminals of the STATCOM. These are controlled for provide concurrent real and reactive

series line compensation without an external energy source. The UPFC, by means of angularly unconstrained series voltage injection, is able to control, concurrently/simultaneously or selectively, the transmission line voltage, impedance, and angle or, alternatively, the real and reactive line flows. The UPFC may also provide independently controllable shunt- reactive compensation.

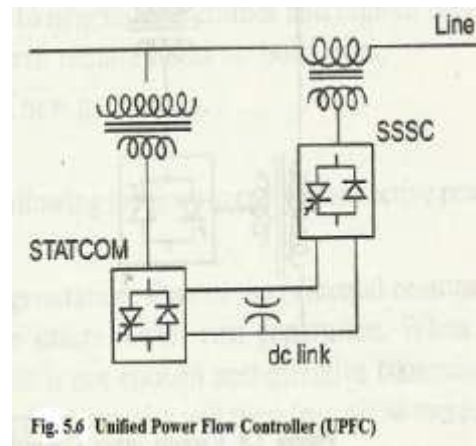

#### 5.4 Converter rating for FACTS technology general comments

Most FACTS applications will involve converters with a rating much higher than 5 MVA. The designer now has many options to meet the needs of the higher rating. These options include-

- (a). Increase pulse-order to 12, 24, or 48, in order to reduce the harmonics to an acceptable level with 2, 4, or 8 six-pulse converters, duly phase shifted, one can concurrently increase the total converter rating to a maximum 10, 20, or 40 MVA, still with one turn-off device per valve.
- (b). Adapting a three-level converter topology also doubles the converter voltage and hence the potential maximum single-device per valve converter capacity to, say 10 MVA per six pulse, 20 MVA per 12-pulse, and so on.
- (c). Connecting devices in series is the most frequently used option for high-power converters. Here the issue is that of ensuring equal voltage distribution among the devices.
- (d). Double the number of phase-legs and connect them in parallel. These phase-legs may be of the two-level or three-level variety.

#### CONCLUSION

In this article, we discussed various principles of FACTS and HVDC pertaining to VSCs in transmission systems. Circuit analysis and Mathematical algorithms are presented for computer simulation purposes to achieve new experimental results. Future work will invite intelligent systems to achieve more optimum and fast systems.

#### REFERENCES

- [1] Chakrabarti, A, D.P. Kothari and A.K. Mukhopadhyay "Performance Operation and Control of EHV Power Transmission Systems" Wheeler, New Delhi, 1995.
- [2]. Hingorani, N.G. and Laszlo Gyugyi, "Understanding FACTS." IEEE press, New York, 2000.
- [3]. Song, Y.H' and A.T. Johns, "Flexible AC Transmission Systems", IEEE London, 1999.
- [4]. Miller, T.J.E., "Reactive Power Control in Electric Systems" John Wiley and Sons, NY, 1992.
- [5]. Nagrath I.J. and D.P. Kothari, "Electric Machines" 2nd edn, Tata McGraw-Hill, New Delhi, 1997.
- [6]. Taylor "Power System voltage stability" McGraw-Hill, Singapore, 1994.
- [7]. Nagrath, I. J and D.P. Kothari "Power System Engineering" Tata McGraw Hill, New Delhi, 1994.
- [8]. Indulkar, C.S. and D.P. Kothari, "Power System Transients A Statistical Approach," Prentice-Hall of India, New Delhi, 1996.
- [9]. Mathur, R.M' and R.K. Verma, "Thyristor-Based FACTS; Controllers for Electrical Transmission Systems" John Wiley, New York, 2002.
- [10]- Edris- A-, "FACTS Technology Development: An Update". IEEE Pott'er Engineering Review'. Vol. 20. March 2001. pp 9.
- [11] - Ilceto F- and E. Cinieri, "Comparative Analysis of Series and Shunt Compensation Schemes for AC Transmission systems". IEEE Trans. pAs 96 (6). pp 18-10.

- [12]. Kimbark, E.W.. "How to Improve System Stability without Risking Subs-synchronous Resonance". IEEE Trans.,Sept/Oct 1977. pp 160.S-1 9 .
- [14]Bhagwat,P.M, and Stepanovic,V.R,"Generalized structure of a multi-level PWM inverter"IEEE transaction on Industry applications,vol. IA-19,no.-6,pp. 1057-69,Nov-Dec 1983.
- [15].Kimbark, E.W. "A New Look At Shunt Compensation.", IEEE102. No. 1. Jan 1983. pp 212-218 . 2, Feb. 2000,
- [16]. Weimers L., *HVDC Light: A New Technology for a Better Environment*, IEEE Power Engineering Review, 1998, 18(8), pp. 9-20.
- [17]. Schettler F., Huang H., Christl N.,"HVDC transmission systems using voltage sourced converters design and applications, IEEE Power Engineering Society Summer Meeting, 2000, 2, p. 715-720.
- [18]. Asplund G., "Application of HVDC Light to power system enhancement"IEEE Power Engineering Society Winter Meeting., 2000, 4, p. 2498-2503.
- [19].Weimers L."New markets need new technology" International Conference on Power System Technology, PowerCon, 2000, 2, p. 873-877.
- [20]. Smith D., *Cross Sound HVDC Link Extends IGBT Power*, Modern Power Systems – Transmission & Distribution, pp. 31-36, October 2000.
- [21]. M. Byggeth, K. Johannesson, C. Liljegren, U. Axelsson, "Gotland HVDC Light – The World's First Commercial Extruded HVDC Cable System", [CIGRÉ 2000, Paper no. 14-205]
- [22]. B. Railing, J. Miller, G. Moreau, J. Wasborg, Y. Jiang- Häfner, D. Stanley, "Directlink VSC-Based HVDC Project and Its Commissioning", [CIGRÉ 2002]
- [23].Asplund G, Eriksson K, Svensson K"DC Transmission based on Voltage Source Converter"(1997) CIGRE SC14 Colloquium in South Africa 1997:"
- [24]. L. Gyugyi, "Dynamic compensation of ac transmission lines by solid-state synchronous voltage sources", IEEE Trans. On Power Delivery, Vol. 9, No. 2, April 1994
- [25]. V. Khatri, V.K. Sood, H.Jin, "Analysis and EMT simulation of a conventional gate firing unit for HVDC converters operating with weak AC systems", Canadian Conference on Electrical and Computer Engineering, Vol.1, Sept. 1994, pp 173 – 177
- [26]Ekstorm,A., "Theoretical analysis and simulation of Forced commutated voltage source converters for FACTS application",EPRI FACTS conference 1:The future in High voltage Transmission, Cincinnati, November 1990.
- [27] Lafon L,Maire, J. ,Le Du ,A. and Coquery.,G. "Investigation into technology and specifications of self commutated valves of potential applications in high voltage power systems"CIGRE 1995 Symposiums on Power electronics in Electrical Power systems,Tokyo,May 1995.
- [28] Srinivasa Rao Karumuri, P. Sri Sairam and Y Srinivas"Design and simulation of process control using a PID controller by COMSOL multiphysics" Advances in Applied Science Research , Page No: 1910-1914
- [29] Ochala, I., Gbaorun, F and Okeme, I. C "Design and implementation of a filter for low-noise applications" Pelagia Research Library,Advances in Applied Science Research 62