



Pelagia Research Library

Advances in Applied Science Research, 2010, 1 (2): 84-91



Power supply system for AC coaches

Pranav Kumar Asthana

*Department of Electronics & Communication Engineering
Bundelkhand Institute of Engineering & Technology ,Jhansi
Uttar Pradesh-284128, India*

ABSTRACT

The power supply technology used in train interiors have indirect coupling with axle. This makes system lesser efficient and bulky. The paper deals with improvement in the performance of power supply system. Magnets mounted on axles with stator of slotted hollow cylinder will make alternator that will be robust and light weight. This cheaper system will be simple and easy to use. The problem of alternator pulley and axle pulley damage can be solved. The output voltage from alternator will have a many frequencies .Hence we will pass it through converter cum regulator insuring total elimination of harmonics . The pure DC output from it will be feed to batteries and supply.

Key- words: Alternator, Alternator pulley, Automatic electrical feedback system, Axle pulley, Cut-in speed, Electronic switching system.

INTRODUCTION

In the present scenario the biggest problem is of energy crisis, the roundabout cause for climate change. The energy can be conserved by enhancing the productivity of systems .Since now day's locomotive engines are replaced by electric trains because of better performance of engines. Hence the main focus of engineers is to reduce the electricity requirement and make trains more efficient. For that they experimented mainly on size and weight but results upgraded only little performance.

The concept of automatic feedback electric systems is very innovative in this field it's never used in past. It is a feedback system because rotational energy is output of train while it is input for alternator and output of alternator, electricity is again transferred to power supply system of train. .The production of electricity from this system is also at the time of breaking. Since trains

have very fluctuating speed hence this electricity produced will also be fluctuating in nature so we cannot feed this to supply directly.

Problem Formulation

A pulley fitted on the axle of the coach to drive the alternator by V-belts(Axle pulley) and then a pulley fitted on alternator and driven by axle pulley through V- belts (Alternator pulley). In this way alternators are indirectly coupled to axle making poor efficiency of overall system and very complex mechanical structure, which results huge mass of the system .The weight of currently used alternator is almost 500 kg with maximum limit of 525 kg [2].This all makes and finally the awful cost.

Problem Solution

3.1 Objective of the work

To make power supply system for trains with betterment in scales of efficiency, cost, safety, weight, simplicity and reliability.

3.2 Methodology

Rotating axles of the trains can be the source of rotational(mechanical) energy for a alternator, this is the key idea of the project. Generally trains have 400-1500 rpm in normal speed. If we cover the axle by hollow cylinder with conductor slots and rotor mounted with permanent magnets then this will make a alternator [1]. A thin layer of insulation is provided to axle from rotor for high quality safety purpose. Holders confirm the connectivity of magnets and axle. Stator keeps interaction with magnetic field with the aid of hollow cylinder. This is shown in the Fig 1. The battery is connected to the alternator through rectifier-cum-regulated unit, which converts AC output of alternator into regulated DC and prevents the reverse flow of current from the battery to the alternator during periods of non-generation. This is shown in Fig.2. The design with regulator cum rectifier has magnetic amplifier type control on field excitation. Subject to the condition that total current of alternator is less than rated current output the regulator shall regulate the output voltage of the alternator so as to maintain a pre-set voltage subject to the tolerance at the rectifier terminals under the following conditions.

- a) At all speeds from 800 RPM to maximum speed.
- b) At all loads ranging from 10A to the rated output of alternator [2].

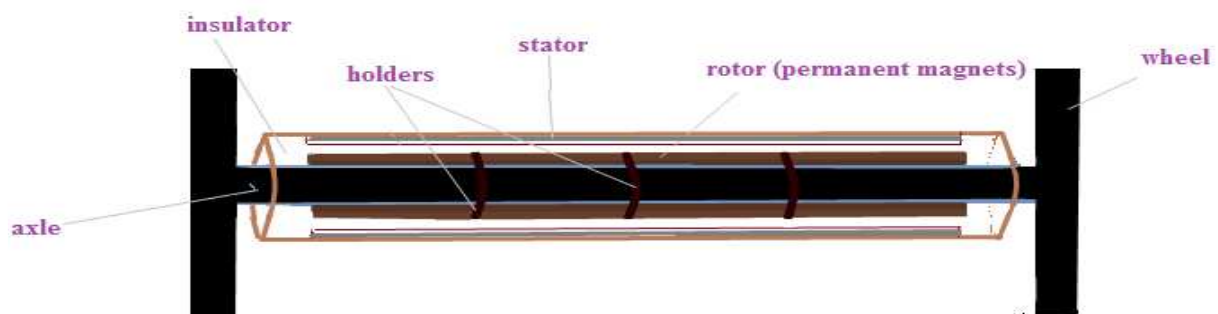

Fig. 1. Axle of the train and position of generator system

Alternator produces electricity, variable in amplitude and frequency of wave form. The rectified output is still having much ripples, hence a regulator is used. This produces pure dc of 130 V.

The regulator produces same output when input voltage is below 130 V. At very slow speed and at the time of breaking the output of rectifier cum regulator will be less than 30 V. This de-energizes to relay, used between regulator and main battery as a switch and now the output of rectifier is feed to secondary battery charger. This is shown in the Fig. 3. The pure DC is used for supply and battery charging. For better service we should have a good control and regulation on the final waveform. Although nominal condition for voltage in ac coaches is 110 Volt but rating is of 130 Volt. The need for voltage control is quite evident, for high quality it should work in automatic and manual mode.

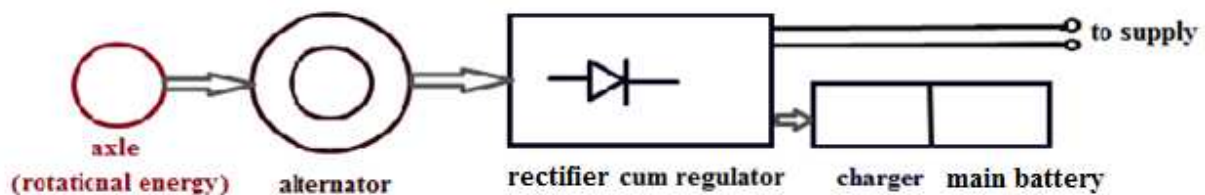

Fig 2. Block Diagram of power supply system

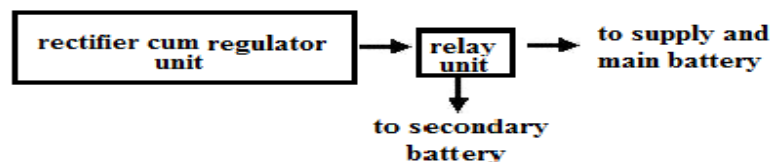

Fig.3. Relay mechanism for efficient energy management

A three-phase optically isolated power rectifier cum regulator with linear characteristics is shown in Fig. 4.

In this power regulator, the power stage and signal stages are isolated via light-activated S21ME3G triacs. Linear transfer characteristics are achieved using the cosine-wave crossing method of triggering the triacs. In Fig. 5, operation of one of the power regulator's three sections is explained using various waveforms. Waveforms of the other two sections of the power regulator are similar to Fig. 2, but delayed by 120° and 240° respectively. Figure 5 a shows typical three phase line waveforms. These line voltages are stepped down using three transformers. Full-wave rectified output of line the L1 transformer is shown in Fig. 5 b). This is compared with a small voltage V_q to generate advance and retard angles. Advance and retard angles, q_a and q_d , are required to make sure that there is some voltage across the triac before it is triggered. Figure 5 c) shows the advance and retard angle for phase L1. A further comparator generates a reference waveform, VC_5 , required for the isolation of two half cycles of cosine waves. Two 180° -shifted biased cosine waves are generated using two integrators, Fig. 4. Both 5kW potentiometers of each integrator should be adjusted to obtain integrator outputs as in Figs 5 e) and f). Using reference voltage VC_5 and a 4053 multiplexer, two cosine waveforms are combined to generate a reference cosine triggering waveform Fig. 5 g). This is needed to achieve the power regulator's linear transfer characteristic. Voltage V_c and the reference cosine waveform are compared to generate the respective firing angle, b , as in Fig. 5 h). An AND function using two diodes and a transistor produces advance and retard angles. The resulting waveform, Fig. 5 i), is used for triggering the triac connected to phase L1 of the supply. Three

similar sections of the power regulator make sure that all three triacs are fired at exactly equal delay angle α . We used a 5N6344 power triac in the original design. It is capable of carrying 10A load.

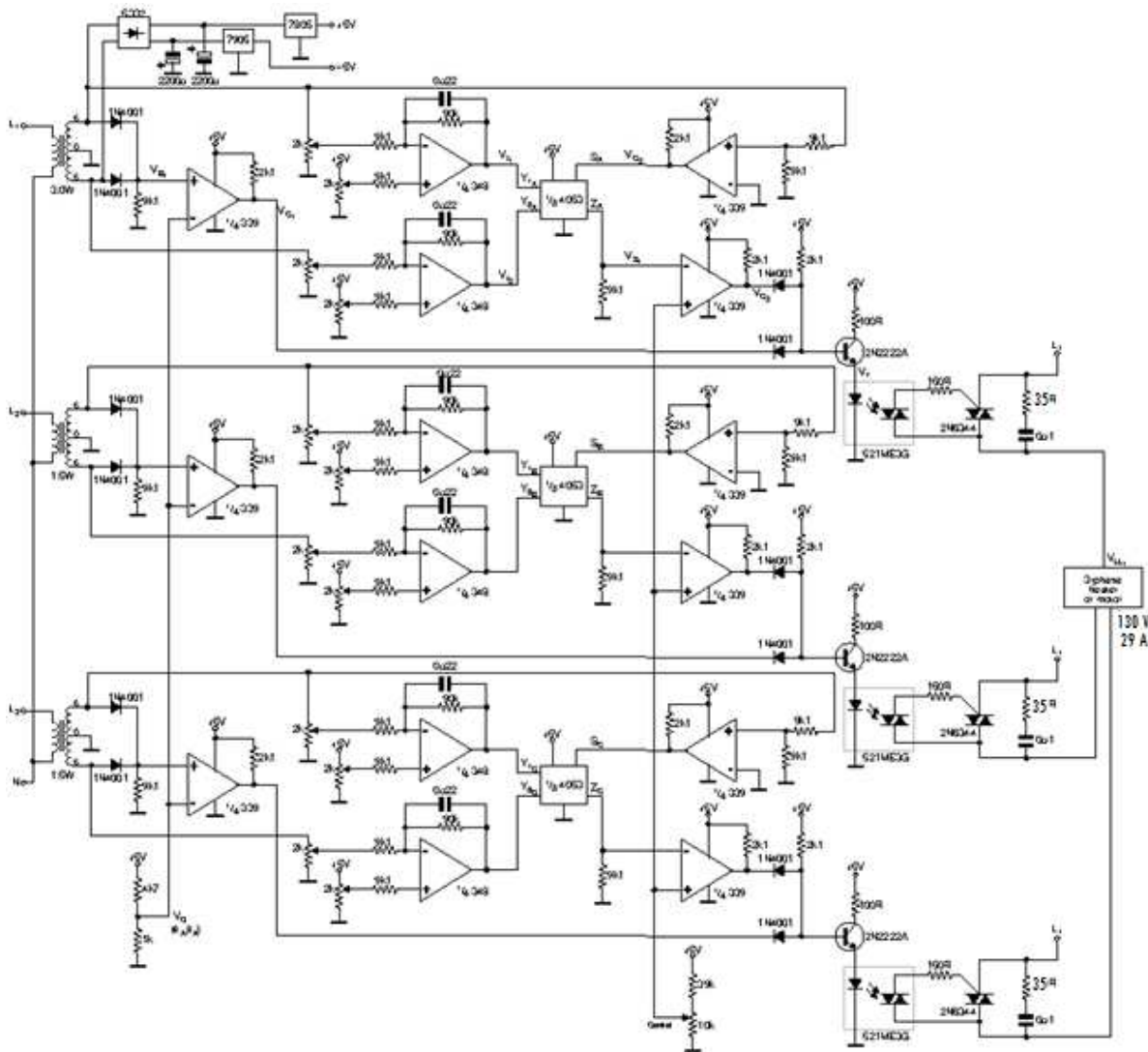

Fig.4. Three-phase linear power rectifier cum regulator control and drive circuitry for resistive loads [3].

Point of general attention is that alternator mounted on different wheels will produce same type of waveform. Hence it is better to rectify waveforms of a group of alternators connected in parallel rather than individual rectification. This will add up current but not to voltage which is really needed because RDSO standard allows full rated output current of 193 A at rated voltage of 130V [2]. So the output from four alternators of a bogie is rectified and regulated. Further higher voltage will hinder the rectification process. Although voltage and current detector is used to limit voltage and current of alternator to pre-set values. Now again output signals from seven different rectifier cum regulator units are paralleled, hence final power supply after adding them in parallel fulfills the rating criteria. The air-conditioning plant and coach fans are connected

across the main positive and negative. The fluorescent lamps are also similarly connected across the main positive and negative. Some of the coaches are fitted with AC fans and lights, which are connected across inverter AC output.

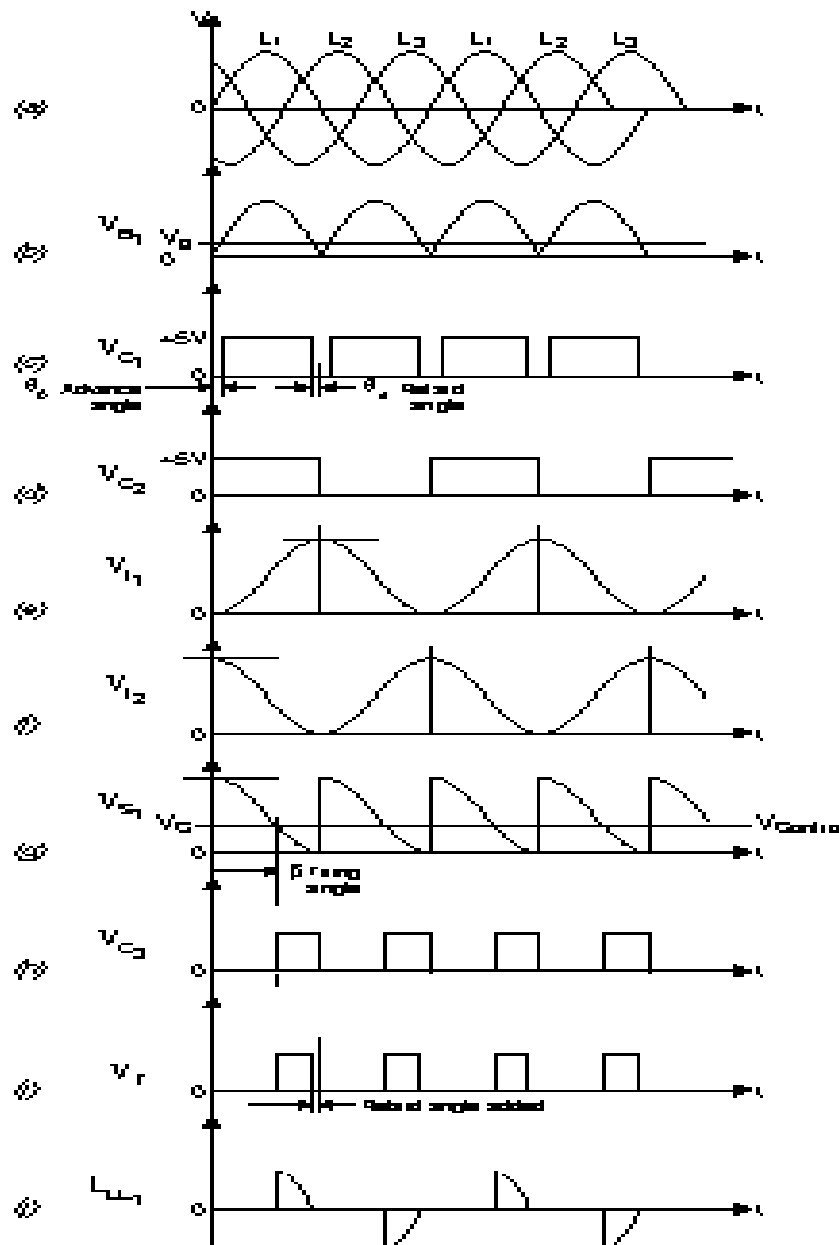

Fig. 5. Timings involved in the three-phase linear power regulator, with mains input at the top and power output at the bottom [3].

3.3 Experimental work

As mentioned earlier the weight of currently used alternator is almost 500 kg. While the predicated weight of this single system will not more then 15-20 kg. If there is any problem of

mechanical loading then whole of alternator can be divided in two parts mounted on same wheel. So the system will not create any type of mechanical loading problem to main engine and to strength of axle. The performance of this will almost same as before. In a single bogie there are 4 axles and with each axle there is a generator so with a train of only 10-20 bogies can also produce sufficient electricity. This electricity can also be used in internal power requirement of the train specially in ac coaches. Most challenging problem for this system is to fit it beneath chassis. But with metal rod support and compact designing of alternator, specially for axles after making slight changes it look easy.

There is a range of speed which affect the output waveform of alternator such as high, variable (accelerating and decelerating), low and reverse speed. The minimum alternator speed in rev./min at which it gives full rated output current of 193 A at rated voltage of 130V is termed as minimum speed for full output or MFO speed. At the time of breaking and very low speed output of alternator will be given to secondary battery by means of relays. The coaches are expected to run up to a maximum speed of 130 km/h in varying climatic conditions exiting throughout India. All accessories to be mounted on the coach under frame shall be designed to withstand service vibrations and buffing shocks. With this technology the solution is more efficient and simple. Also in previous system the rotor and alternator pulleys, shall be dynamically balanced separately on a balancing machine. There is no such problem in this system.

The point where we have to put attention is safety because the mechanism will carried on at axles hence the proper focus will be on the isolation of conductors. U-shape metal rod provides stability to hollow cylinder by melting it to chassis. As shown in the Fig. 6 this system is supported by chassis of the train. Enclosure of rectifier-regulating equipment shall be protected against ingress of solid foreign bodies and water. A safety chain will be used at the time of emergency, this will open circuit armature windings resulting break in the generation of electricity. Temperature sensors are used to measure the temperature of alternator system, one at the surface of stator and second inside the hollow cylinder. They work on see-back effect. Signals from sensors get amplified by 12 V supply, this is also necessary for differentiating signals from noise. Now these are converted into digital form and then processed through comparators if they are above a certain level it will break the connections. We need cooling of alternator for better efficiency and safety purpose. For it fan cooling is used. This is shown in the Fig. 7. When axle rotates, fans also rotate since orientation of fans are same hence one sucks air and second exhausts it, hence flowing air cools the alternator. When train will be in reverse motion the working of fans will be reversed but still air cooling will be there. If we use powerful fans then thrust by exhauster can create many problems like tremendous force on left wheel. Then it will work like a jet engine causing great thrust and creating extreme force at some angle with horizontal first unbalancing the train finally derailling it. Hence we used here two light weight blades with small dimensions so that sucking and exhausting air will small in content and with mild rate of flow. Hence there will be air cooling only and no simulation of jet engine. At the boundaries of alternator net is used as protective shield. This prevents alternator by small objects and mild the air flow and content.

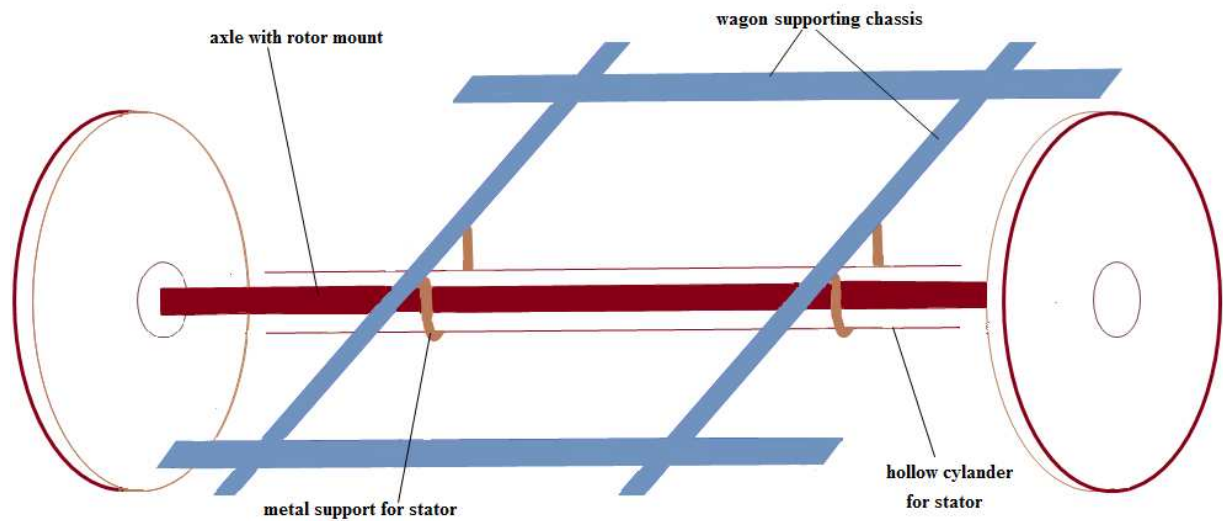

Fig. 6. Stator supporting metal's position. The insulated cylinder is welded with this metal.

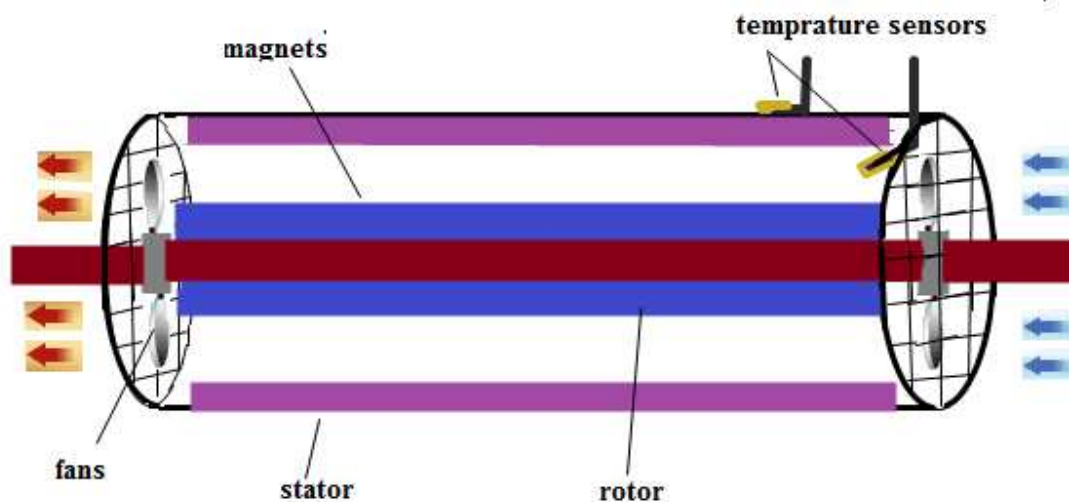

Fig.7. Fan cooling for increasing the performance and position of temperature sensors.

RESULTS

The output voltage of power supply system is 130 V and almost 195 Amperes of current with 7 parallel rectifier cum regulator units, in normal conditions. Theoretically we will get 203 A but due to lose the current is same as above. The use of relay mechanism makes this system smarter. The efficiency of the alternator and regulating equipment combined together is not less than 80% at 130V, 193A and 1800 rpm. The ripple content in dc output voltage are not exceed 3%. Current limiting protection shall be provided to limit the output current to the rated value & with tolerance of 50%. These all fulfill criteria of RDSO.

CONCLUSION AND FUTURE WORK

The weight of currently used alternator is almost 500 kg while the predicated weight of this single system is less than 15-50 kg. Now there is no need to design a rotor and its stabilizing accessorizes, the axle will work for rotor. The output of regulator is provided to supply and charging unit while at the time of zero movement of the train battery is used for supply. The cut-in speed and MFO speed of the alternator shall be as low as possible consistent with economical design. By means of this design the performance of train can be drastically enhanced with attention on safety. Hence we will be able to not only reduce mechanical complexities but also cost and weight of power supply system will be also drastically drop. With all this trains can come with super efficiency power supply system.

Acknowledgments

First of all I would like to thanks Dr. Shahanaz Ayub, Department of Electronics & Communication Engineering Bundelkhand Institute of Engineering & Technology, Jhansi for her immense guidance for preparation of this research paper. Secondly I am highly obliged to God for igniting the spirit for science. Last but not the least I am thankful to my family members and my friends for their support.

REFERENCE

- [1] Bimbhra, P.S: Electrical Machinery, 7th ed., Khanna Publishers, New Delhi, **2005**. pp. 544-545.
- [2] Specification for 25 KW brushless alternator with rectifier cum regulator equipment for 110 volt DC SG AC coaches, Power supply and EMU directorate, Research Designs and Standards Organization, Ministry of Railways Lucknow, July **2004**,pp.5,6,11.
- [3] Iqbal Tariq , Three Phase Power Regulator, *Electronic World*, August **2000**, pp. 560-561.