

Mathematical models for predicting pollutants movement through porous rocks

Onwuka S. U., Okoye C. O. and Onwuemesi F. E

Department of Environmental Management, Nnamdi Azikiwe University; Anambra State, Nigeria.

ABSTRACT

Owing to the careless siting of human activities in Anambra State, resultant pollutants pass through porous rocks to pollute the underlying groundwater. Consequently, an infiltrometer was used to investigate the velocities of pollutants (four fluids) through five sedimentary formations of varying lithological characteristics, with a view to constructing a mathematical model for predicting the movement of pollutants through the porous rocks in the area. A purposive/judgmental sampling technique was used to select the formations used. Consequently, two mathematical equations useable to predict travel times and travel distances of pollutants were constructed so as to safeguard the groundwater resources of the area. The study recommended that in the planning and management of the physical environment of the state, knowledge of pollutants' vertical velocity through porous rocks should be integrated into water resources management. This is to say that shale terrains or any other formations that have, at most, porosity and hydraulic conductivity values of 18% and 2.3×10^{-8} cm/sec. respectively, should be used for such activities. It also recommended that site selection for such anthropogenic activities should be based, among other things, on the knowledge of underlying geology of the place in question, and not merely on the availability of such space and close proximity to users. Further research areas were also recommended.

Keyword: Pollutants, porous rock, mathematical model, water resources and lithological characteristics

INTRODUCTION

Many developing and industrialized countries of the world indiscriminately site human activities that generate mobile pollutants. There is no doubt that both the urban and rural areas of such countries have been adversely affected by these resultant pollutants and contaminants, resulting in losses in human, material and financial resources. Huge amounts of money are spent annually for research to combat and control widespread incidence of pollutants and contaminants in many of such places. This is because volumes of the resultant pollutants are continuously produced yearly through many human activities, including industrial activities, agricultural practices, waste disposal systems, etc. Consequently, various levels of wastes in different states, including solid, liquid and gaseous, are released into the environment at discrete intervals or on continuous basis. These pollutants and contaminants, which may have short or long half-lives in the environment, have continued to damage the environment of the industrialized countries, having defied many painstaking control programs (*Egboka et al, 1989 and Fano et al, 1987*).

In addition, geologic and hydrologic cycles have several components and characteristics that enhance or aggravate the incidence of pollutants and contaminants origin, transport, and spread through hydrodynamic dispersion (diffusion, advection and dispersion) into the hydrogeologic environments that embrace the atmosphere, pedosphere, lithosphere, hydrosphere and biosphere.

Consequently, these resultant pollutants/contaminants, in one way or the other, via the hydrologic cycle, reach the groundwater system to pollute/contaminate them. This is to say that these pollutants/contaminants move, via porous

rocks, through the circulation of water within the hydrologic cycle. Pollutants on the ground surface are transferred through the soil zone into the aquifer horizons where they damage potable water sources. This is exactly the case of Anambra State which is underlain by sedimentary rocks of varying lithological characteristics, especially sandstone.

Sequel to the above, there is need to come out with a management strategy to protect these water sources since groundwater has become the main, if not the only, reliable source of water for various uses in the state, especially in the urban-areas. Part of this strategy is to construct mathematical models for predicting pollutant s' movement through porous rocks. When this is done, both vertical travel distance and travel time taken by a known pollutant/contaminant can be calculated. The time for a known pollutant to travel to an aquifer of a known distance can be calculated once their lithological characteristics are known. In doing this, the groundwater resources can be protected. Moreover, people living within the areas underlain by porous rocks, and who use groundwater can be protected from ingesting pollutants.

Study Problem

As a result of the wrong assumption that groundwater is always free from pollution, its use has tremendously risen across the globe for various purposes: domestic, industrial, agricultural, etc. Contrary to this assumption, studies by different people in both developing and developed countries of the world show that pollutants from various sources get to the groundwater, with time, and pollute it. For example, works by Elrik and French (1966), Thoma and Phillips (1979), Egboka et al., (1989), Trenthan and Orajaka (1986), Orajaka (1986), and Shell Petroleum Development Company (SPDC) (2003 and 2005) have proved this. Ajiwe et al (2006) explained that industrial effluents released into the environment get to the groundwater with time, and pollute it; hence they recommended that the velocity of these pollutants be established. However, even if the velocities of such pollutants are known, if there are no mathematical models for predicting their movements much may not be achieved.

A casual look at most urban centres in Nigeria, and indeed in Anambra State, reveals unplanned and unorganized uses of various locations for various purposes like solid waste dumping, effluents disposal, siting of burial grounds for dead bodies, siting of widescale toilet facilities, disposal of chemical wastes from human activities, and wrong and frequent application of artificial fertilizers. These are done without putting the lithological characteristics of the underlying formations of such sites into consideration.

There is no doubt that these activities take place either in recharge waters or in groundwater recharge areas. Considering the concept of hydro-geopollution cycle, these resultant pollutants are circulated via the hydrologic cycle as confirmed by Onwuka (2009). Hence, groundwater is ever at risk in these porous rocks as confirmed by Ajiwe et al (2006) and Onwuka et al (2007) in Onitsha. Unfortunately literature is not rich with useable equations for calculating both travel times and distances for vertically moving pollutants on these porous rocks.

It is to this effect that this paper comes up with mathematical models for predicting pollutant s' movement through porous rocks. This helps to calculate both vertical travel distances and travel times taken by a known pollutant/contaminant to move from one point to another. In this way, the time for a known pollutant to travel to an aquifer of a known distance can be calculated once their lithological characteristics are known.

The aim of this paper is to construct mathematical models for predicting vertical movements of pollutants through porous rocks of Anambra State with a view to establishing a reliable strategy for groundwater resources management strategy in the area. The following objectives were pursued to achieve the aim:

- to establish formations where mobile-pollutants-generating activities are carried out,
- to establish the porosity and hydraulic conductivity values of the formations,
- to determine velocities of pollutants through the formations, and
- to construct mathematical models for pollutants' movement prediction.

Area of Study

This study is carried out in Anambra State. The area is located between latitudes $05^{\circ} 40'N$ and $07^{\circ} 10'N$ and longitudes $06^{\circ} 35'E$ and $07^{\circ} 20'E$ (Figure 1). Anambra State is made up of 21 local government areas. The state is located in south-eastern Nigeria.

Two climatic seasons exist in the study area, namely rainy season (March- October) and dry season (November-March). The dry season is characterized by heavy down pours; it is also accompanied by thunder storms, heavy flooding, soil leaching, extensive sheet outwash, ground infiltration and percolation (Egboka and Okpoko, 1984). The annual rainfall of the area is over 2000mm

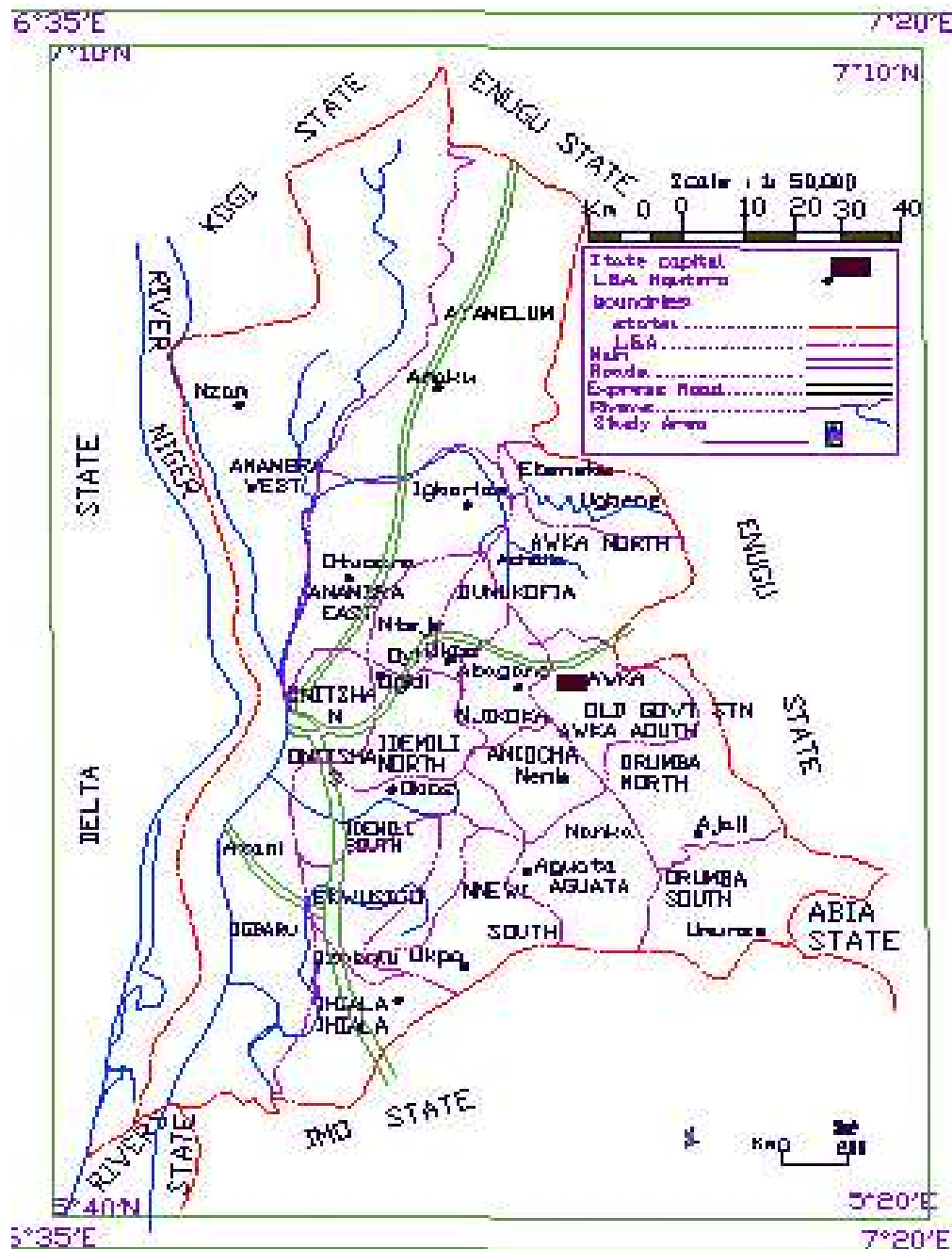

Fig 1: Map of Study Area
 Source: Nigerian Survey Agency, 2006)

The study area lies within the rain-forest belt of Nigeria. In the south, the area is bounded by mangrove swamp forest, and in the north, by savannah grassland.

Anambra State is underlain by sedimentary formations of varying types and ages. Consequently, most of the formations, being mainly sandstone are good aquifers of high economic viability. Typical examples, according to Jones and Hockey (1964) and Onyeagocha (1980) are Nanka Sands, Ogwashi-Asaba Formation, and Ameki Formation. The geologic map of Anambra State is shown in Figure 2 below. It also contains the formations used for the study. The natural flow patterns of the rivers and their tributaries are dendritic drainage pattern (Igbokwe et al, 2008).

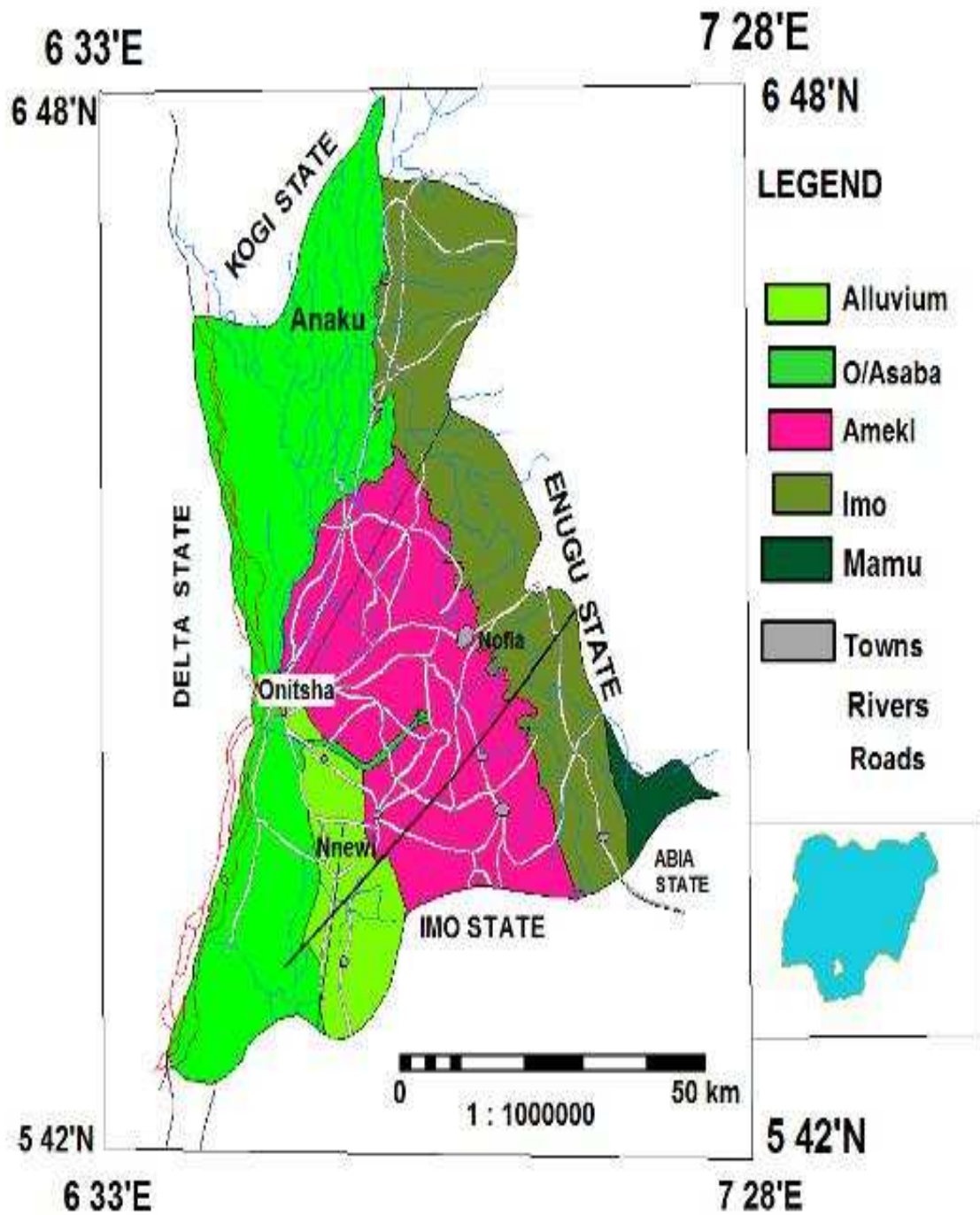

Fig. 1.2: Geological Map of Anambra State
 (Source: Nigerian Survey Agency, 2006)

As a result of these anthropogenic activities, there is continuous and increased generation of mobile pollutants. These pollutants are either indiscriminately released into the water bodies, or carelessly dumped on the earth surfaces. Now owing to the high porosity and permeability of the formations in the area, these mobile pollutants, via the hydrologic cycle, penetrate to the groundwater resources and render some deleterious for various direct and indirect human uses.

Conceptual Framework of the Paper: Darcy’s Law

This research work is based on Henry Darcy’s Law of Fluid Motion or Rate of Flow. In fact, the experimental set up and the mathematical formulae used are the ones got from this law, although there were some modifications.

Henry Darcy, a French engineer, propounded in 1856, a relationship between rate of flow of water through a porous medium with other parameters such as hydraulic gradient and length of the column of the medium. His experimental observations have been established as Darcy’s Law, and forms a fundamental equation in the flow of groundwater. According to this law, the rate of flow of groundwater through a column of saturated medium is:

1. directly proportional to the difference in hydraulic head at the ends of the column, and
2. inversely proportional to the length of the column

This means that fluid motion in a saturated geological material (consolidated or unconsolidated) is dependent on the hydraulic gradient, porosity and hydraulic conductivity of the geological material. The experimental set-up is shown diagrammatically in Figure 4:

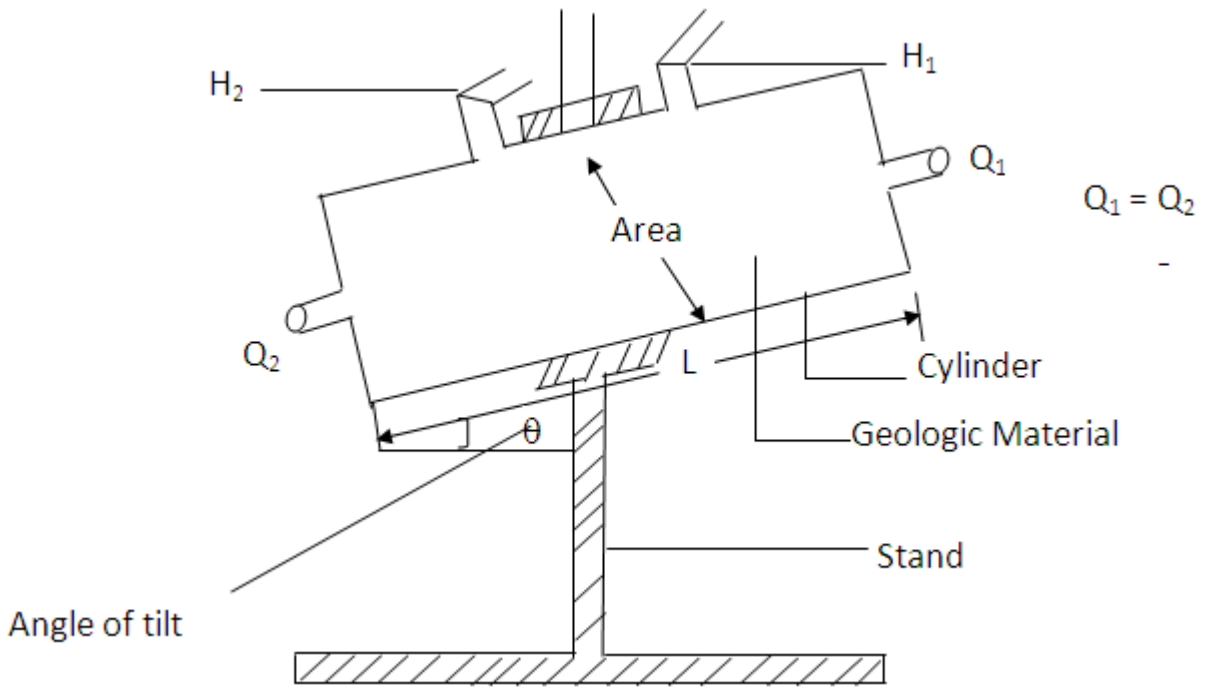

Fig.4: Darcy’s Experimental Set-up
(Adapted from Freeze and Cherry, 1979)

A metallic cylinder of cross-sectional area, A, is filled with a geologic material (unconsolidated rock sample), and made to be tilted at an angle, θ , to the horizontal. The cylinder is made to have two hydraulic heads at the ends, in order to assume atmospheric pressure.

The material is saturated with water by allowing water to flow through Q_1 . At the instance the water flows out through Q_2 , then $Q_1 = Q_2 = Q$.

Putting Darcy’s law mathematically,

Where:

$$V = \frac{h_1 - h_2}{KL} \quad \text{-----1 (Darcy, 1856)}$$

- V = Flux Velocity or Specific Discharge
- K = hydraulic Conductivity
- $h_1 - h_2$ = difference in Hydraulic head.
- L = length of the column.

Hydraulic gradient, which is the difference in hydraulic heads at two points, divided by the length, is often called hydraulic gradient, L, hence equation 1.1 becomes:

$$V = KL \quad \text{.....2}$$

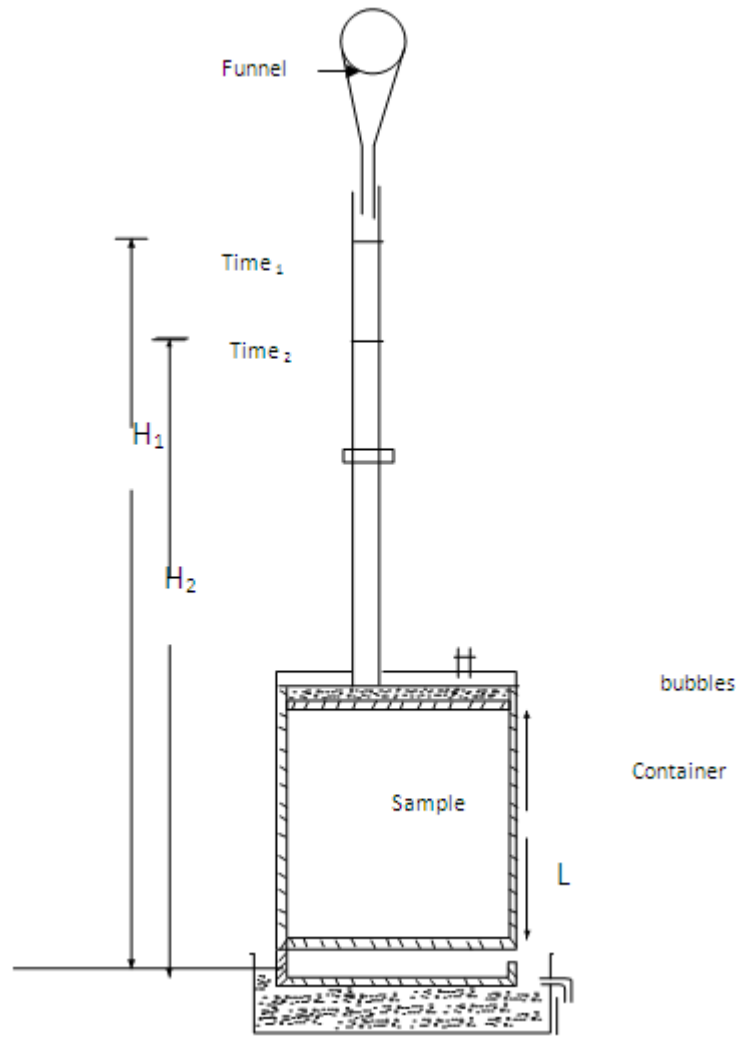

Fig.4: Falling Head Permeameter (Adapted from Garg, 2004)

According to Garg (2005), in a pipe flow condition, which is analogous to flow in a porous medium, the discharge, Q, is given by:

$$Q = V.A \dots\dots\dots 3$$

Where:
 A = the cross sectional area of the cylinder.
 V = the velocity or specific discharge.

From the above equation, the relationship of discharge to hydraulic conductivity is easily established thus:

$$Q = KLA \dots\dots\dots 4$$

According to Singh (2004) this relationship is of fundamental importance in groundwater studies, particularly in a study of this type. Here, Q represents discharge, and it is expressed as discharge per unit of time, such as cubic meters per second. As said before, K is the hydraulic conductivity, and it indicates the quantity of water that will flow through a unit cross-sectional area per unit of time under a unit hydraulic gradient at a specified temperature.

In order to study the pollutants' velocity via porous rock, a laboratory set up that is based on Darcy's law, which is called variable/falling head permeameter was used. This is because to understand the pollutants' vertical velocity, the relevant parameters of geologic material which Darcy's set-up used in measuring groundwater velocity are also inevitable. For instance, the hydraulic conductivity of a rock depends on a variety of physical factors like particle size and distribution, porosity, permeability, shape of particles, arrangement of particles, etc. (Luszczynski, (1961); Rummer and Harleman, (1963). In general, for unconsolidated porous media (used in the hydraulic conductivity

measurements) which essentially defines the above parameters, hydraulic conductivity varies with particle size (David, 1980).

From the foregoing, therefore, a study of this type will be suitable in studying the behaviour of wastes from various sources like waste disposal sites, industrial effluents, clinical wastes, wastes from mining activities, and wastes from oil exploitations, etc.

This is because, according to Egboka *et al* (1989), porosity and hydraulic conductivity are properties that are dependant on the geologic conditions of such waste disposal sites. So, the differences in hydraulic conductivity values across a stratigraphic section could appreciably determine whether it is upward, downward, or horizontal as demonstrated by Freeze and Witherdpoon (1967). But in this study, interest is in downward flow or vertical movement of pollutants; hence instead of tilting the cylinder to an angle θ as in figure 1.4, the sup-up is vertical, figure 1.5.

MATERIALS AND METHODS

Experimental design was adopted in this study. Due to the nature of the study, a judgmental/ purposive sampling technique was chosen in selecting the formations with which the laboratory analyses were run. This is because, according to Babie (1973: 106) purposive sampling is the most suitable in a study of this type.

Thus, if $\frac{dH}{dt}$ represents the rate of fall of head, the rate of flow will be given by

(-) $a \cdot \frac{dH}{dt}$ the negative sign means that the head falls with time. Equating this to the flow in accordance with Darcy's Law, we have

$$-a \frac{dH}{dt} = k \cdot \left[\frac{H}{L} \right] \cdot A \quad (1)$$

Where:

A = the inside are of the burette (But in real life, it will be the inside area of the source of pollutant).

H = difference in fluid level (in real life, it is the hydraulic gradient).

L = length of the cylinder (in real life, it is the vertical thickness of the formation through which the fluid flows).

A = Area of the cylinder (in real life, it is the surface covered by the fluid, i.e. the surface area through which it seeps to pollute the groundwater).

K = The hydraulic conductivity of the rock sample (In real life, it is the hydraulic conductivity of the soil or formation through which the pollutants flow).

$$\therefore a \frac{dH}{H} = -K \cdot \frac{A}{L} \cdot dt \quad (2)$$

Integrating between H_1, H_2 and t_1, t_2 , we get,

$$a \int_{H_1}^{H_2} \frac{dH}{H} = -K \cdot \frac{A}{L} \cdot \int_{t_1}^{t_2} dt \quad (3)$$

$$\text{Or } a \cdot |\text{Log}_e H|_{H_1}^{H_2} = (-)K \cdot \frac{A}{L} \cdot |t|_{t_1}^{t_2} \quad (4)$$

$$\text{Or } a(\text{Log}_e H_2 - \text{Log}_e H_1) = (-)K \cdot \frac{A}{L} (t_2 - t_1) \quad (5)$$

$$\text{Or } K = \frac{(-)aL \text{Log}_e \frac{H_2}{H_1}}{A \cdot (t_2 - t_1)} = \frac{aL \cdot \text{Log}_e \frac{H_2}{H_1}}{A(t_2 - t_1)} \quad (6)$$

$$\text{Or } K = \frac{2.3aL \text{Log}_{10} \frac{H_1}{H_2}}{At} \quad (7)$$

$$\text{Or } K = \frac{2.3aL}{At} \text{Log}_{10} \frac{H_1}{H_2} \quad (8)$$

Making t, the flow time, the subject:

$$t = \frac{2.3aL \text{Log}_{10} \frac{H_1}{H_2}}{AK} \quad (9)$$

But $\text{Log}_{10} \frac{H_1}{H_2}$ = hydraulic gradient; replacing $\text{Log}_{10} \frac{H_1}{H_2}$ with i., we have:

$$t = \frac{2.3aL \text{Log}_{10} \frac{H_1}{H_2}}{AK} \quad (10)$$

But Velocity = $\frac{\text{traveled distance}}{\text{time taken}}$

$$\Rightarrow V = \frac{d}{t} \quad (11)$$

$$\Rightarrow t = \frac{d}{v} \quad (12)$$

Equating eqn 4.10 and 4.12 :

$$\frac{d}{v} = \frac{2.3aLi}{AK} \quad (13)$$

If d = L

Eqn 4.13 becomes:

$$\frac{L}{v} = \frac{2.3a \cdot i}{AK} \quad (14)$$

$$\therefore V = \frac{AK}{2.3ai} \quad (15)$$

And

$$d = \frac{AKt}{2.3ai} \quad (16)$$

Equation 15 is the equation that could be used to calculate the velocity of pollutant when:

- (1) The hydraulic gradient of the formation is known
- (2) The hydraulic conductivity of the formation is known.

Equation 16 is the equation that could be used to calculate the distance travelled by a pollutant provided that:

- (1) The hydraulic gradient of the formation is known:
- (2) The hydraulic conductivity of the formation is known
- (3) The traveled time of the pollutant is known.

4.8 Testing the Two Formulae

Taking any values from the above, the accuracy of equation 15 can be confirmed thus:

Calculated A = 176.79; K = 0.0054, a = 12.57, and Hydraulic gradient at that point = 0.9542.

Substituting these in the formula below, we have;

$$V = \frac{AK}{2.3ai}$$

$$\frac{176.79 \times 0.0054}{2.3 \times 12.57 \times 0.9542}$$

$$\approx 0.035 \text{cm/sec.}$$

The 0.035cm/sec. obtained is approximately equal to the laboratory velocity value obtained which is 0.03845.

The implication of this is that the vertical velocity of known pollutants and density travelling through any sedimentary formation (terrain) can be calculated if the following are known:

- i. the cross-sectional area covered by the pollutants
- ii. the hydraulic conductivity of the formation (rock) through which the pollutants travel
- iii. the cross-sectional area of the supplying medium (pipe)
- iv. the hydraulic gradient of the formation through which the pollutants travel.

Similarly taking any values from the raw tables (precisely Table 3), the accuracy of Equation 16 can also be confirmed

Calculated A = 176.79; K = 0.0054, a = 12.57; Travelled time = 520.17 and

Hydraulic gradient at that point = 0.9542.

Substituting these in the formula below, we have;

$$d = \frac{AKt}{2.3ai}$$

$$= \frac{176.79 \times 0.0054 \times 520.17}{2.3 \times 12.57 \times 0.9542}$$

$$= \mathbf{18cm \approx 20cm}$$

The 18cm obtained is approximately equals to the distance of 20cm used in the laboratory.

Similarly, the travel vertical distance of pollutants through any sedimentary formation can be calculated provided that the following are known:

- i. the cross-sectional area covered by the pollutants
- ii. the hydraulic conductivity of the formation (rock) through which the pollutants travel
- iii. the travel time
- iv. the cross-sectional area of the supplying medium (pipe)
- v. the hydraulic gradient of the formation through which the pollutants travel.

CONCLUSION

The results of the analyses done showed that different formations do not allow the flow of mobile pollutants at equal rates. Shale formations allow little or no pollutants to pass through them, unlike sandstone formations. Two mathematical formulae useable to calculate the travel times and travel distances of pollutants, including:

$$V = \frac{AK}{2.3ai} \quad \text{and} \quad d = \frac{AKt}{2.3ai} \text{ were determined.}$$

Recommendations

Based on the finding made, the paper recommends that the availability of an open place, or close proximity of such a place to users should not be the criteria for selecting such a site for every human activity, particularly those activities which generates mobile pollutants. Again, the underlying geology of a terrain should be known before selecting such a terrain for mobile-pollutants' generating activities. Any formation whose porosity and hydraulic conductivity values are greater than 18% and 2.3×10^{-8} cm/sec. respectively should not be selected for such activities since such a formation is likely to allow the passage of pollutants through it. However, those values that are less than these are acceptable for such activities. Moreover unguided/unguarded and indiscriminate use of fertilizers, particularly around groundwater recharge areas for urban water supply schemes, like those of Orumba North Local Government Area should be avoided/checked immediately because of alkalisation, salinisation and soil hardness.

In addition, the government should come up with laws capable of prohibiting individuals from indiscriminate siting of industries in areas whose geologic formations are of high porosities and hydraulic conductivity values in human settlement areas, especially in our urban centres.

The environmental impact assessment (EIA) of projects capable of generating mobile pollutants should include, among other things, the potentials of underlying geology of such sites for pollutants' passage before approval is granted. Erosion sites which are known to abound mainly in sandstone terrains should not be used for waste dumping sites as it is the case in many parts of the study area. This is to avoid faster infiltration of the resultant pollutants to pollute the groundwater resources.

Government should quickly sponsor the comprehensive geologic mapping of the entire Anambra State and indeed, the whole of South-Eastern Nigeria (since the entire area is underlain by sedimentary rocks) so as to establish geologic formations which are good for sitting human activities that generate mobile pollutants. This means that the geologic map of the area is of great importance in urban environmental planning and management of the area.

Further research should be carried out on the following areas:

- The effect of chemistry of pollutants on infiltration rate of pollutants.
- The effect of chemistry of formations on infiltration rate of pollutants.
- Pollutants velocity via porous consolidated rocks.

REFERENCES

- [1] Ajiwe, V.I.E., Onwuka, S.U. and Nnodu, V.C. (2006): *World Journal of Biotechnology*. No. 2, Vol. 7, pp.1104-1111.
- [2] Babie. E.R. (1973) *Survey Research Methods*, Belmont Wadsworth Publishing Company,USA.
- [3] Egboka, B.C.E., Nwankwo, G.I., Orajak, J.P. and Ejiofor, A.O. (1989): *Journal of Environmental Health Perspective* no. 83 pp. 39-68.
- [4] Egboka, B.C.E. and Okpoko, E.I. (1984): *Gully Erosion in the Agulu-Nnaka region of Anambra State, Nigeria. Challenges in African Hydrology and Water Resources* (Proceedings of the Harare Symposium, July 1984). IAHS Publications. no. 144.
- [5] Elrick, D.F., and French, L.K. (1966). *Soil Science Society of America Proc.*, vol. 30, pp. 153 – 156.
- [6] Fano, E., Brevster, M., and Thompson, T. (1985): *Water Quality Management in Developing Countries, Part I in Proceedings of the 5th World Congress on Water Resources*, Brussels, Belgium pp. 641-654.
- [7] Freeze, R. A. and Witherspoon, P. A., (1967): *Water Resources Journal*, 3, 623 – 634.
- [8] Igbokwe, J.I., Akinyede, J.O., Dang, B.A., Alaga, A.T., Nnodu, V.C., Ojiako, J.C., Obienusi, E.A., and Onwuka, S.U. (2008): *Nigeria Journ. of Space research*, No. 5, pp 135-151.
- [9] Jones, H.A. and Hokey, R.D. (1964): *The Geology of Parts of South Western Nigeria*, Bulletin 31 pp 101.
- [10] Luszczynski, N.J. (1961). *Journal of Geophysical Research*, Vol. 666, pp. 4247-4256.
- [11] Nnodu, V.C. and Ilo, I.C. (2000): *A multi-disciplinary Journal for Environmental sciences*, Vol. 2, no.3, pp. 6-15.
- [12] Onwuka, S.U., Ajiwe, V.I.E and Nnodu V.C. (2007): *Journal of Chemical Society of Nigeria* Vol.1. no. 1, pp. 49-53.
- [13] Onwuka, S.U. (2009) Vertical Velocity of Pollutants through Porous Rocks: Implications for Water Resources Management in Anambra State: A Ph.D. Dissertation (Unpublished)
- [14] Onyeagocha, A.C. (1980): *Journal of Mining and Geology*, Vol. 77, pp. 147-151.
- [15] Orajaka, I.P. (1986): *Northern Nigeria, Chemical Geology* No. 56, pp. 85 – 92.
- [16] Rumer, R.R., and Harleman, D.R.F (1963): *Journal of Hydraulic Division of American Society of Civil Engineer*, Vol. 89, no. HY6, pp. 193-220.
- [17] SPDC (2003): *Sub-surface Contaminant Investigation of Ogoni Flow Station Burrow Pit, Compressor Station Effluent Discharge Area, Ogoni Flare Site and Osioka Flare Site*. Unpublished Report of SPDC.
- [18] SPDC (2004): *Sub-surface Contaminant Investigation of Ogbotobo Flow Station Spill Site using GPR Technique*. Unpublished Report of SPDC.
- [19] SPDC (2005a): *Surface Contamination of the Oleh Camp Site using GPR Technique*; Unpublished Report of SPDC.
- [20] SPDC (2005b): *Surface Contamination Investigation of Ughelli West Engineered Dumpsite*; Unpublished Report of SPDC
- [21] Thomas, G.W., Philips, R.E. (1979): *Journal Environmental Quality* vol. 8, no. 2, pp. 149 – 152.
- [22] Trenthan R.,C., and Orajaka, I.P. (1987): *Leaching of Uranium from Felsic Volcanic Rocks*. Experimental Studies Uranium 3: 55 – 67.