

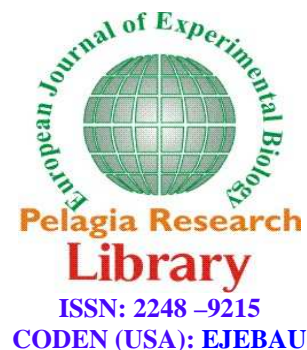

Pelagia Research Library

European Journal of Experimental Biology, 2013, 3(6):462-468



Evaluating the effects of organizational learning on intellectual capital in biotechnological production of Iranian companies

Mohammad Bagher Honarmandyar¹, Marziyeh Hadavand², Saeid Ayati³, Ali Kazemi⁴, Shahram Izadi⁴ and Ali Asghar Negahdary^{4*}

¹Department of Management, Qazvin Branch, Islamic Azad University, Qazvin, Iran

²Department of Industrial Engineering, Iran University of Science and Technology, Tehran, Iran

³Department of Management (Administration), Arak Branch, Islamic Azad University, Arak, Iran

⁴Department of Management, Zarghan Branch, Islamic Azad University, Zarghan, Iran

ABSTRACT

The aim of the present study examines the impact of organizational learning on intellectual capital in companies that produce biotech products. All employees of the study population, biotechnological production of forms With 300 randomly selected employees from the Cochran sampling formula. A total of 280 completed questionnaires were analyzed. Assessment tools, questionnaires, using standard questionnaires organizational learning Neefe(2001) and standard questionnaires Intellectual Capital Bontis (1997) is. Method of study using structural equation is causal. According to the study, mental models of capital structure do not affect the biotechnological production of Iranian companies. Shared vision on human capital does not affect the biotechnological production of Iranian companies. Shared vision on relational capital does not affect the biotechnological production of Iranian companies. Based on organizational learning other aspects of the biotechnological production of Iranian companies have intellectual capital.

Keywords: Organization learning, Intellectual capital, Biotechnology Products

INTRODUCTION

Organizational learning is a dynamic process that enables organizations to quickly adapt to change. This process involves the production of new knowledge, skills and attitudes to be shared by the work you've done and collaborative learning, the strengthening of the results of these two principles, creating a culture of learning and culture is shared among all employees. In the knowledge-based economy, intellectual capital and increase enterprise value is used to create and success of an organization depends on its ability to manage this scarce resource. Moreover, one of the important features of the organization that can create and they have much to contribute and share knowledge with other organizations to create sustainable organizational advantage is organizational learning. Present in the organization are capital's ability to all managers of human elevating strive. Learning conditions are provided for all members of such organizations and individuals continue to apply what they have learned, their efforts. The main feature that can be used in any organization, especially in the context of the "knowledge-based" firms such as biotech crops, there was a very rapid changes, broad, deep and complex the context of their environment. Organizational learning first time by March and Simon (1958) was presented. In other words, research on organizational learning, which started about 30 years and had been increasing [13]. Organizational learning is a special form of learning developed by key individuals in the organization is an organization that can be associated with the following changes [12]. Organizational learning and the learning of new knowledge creation is a priority,

and the role of individuals in creating and applying new knowledge highlights. Organizational learning is an important way to achieve successful performance and provide competitive advantage for organizations. Effective organizational learning is to improve the conditions for innovation and success and to sustain the growing competition recognizes. Learning in organizations is primarily a social activity [12]. Most work is done in such a condition that includes colleagues, managers, customers, vendors (suppliers) and others linked together. Vegatsky (1978) asserts that the cognitive learning that occurs at the community level. Intangible aspects of the economy have been established based on intellectual capital and its primary material, knowledge and learning ability. Organizational learning is the knowledge of irregularities. This included leveraging the knowledge and applies it. Organizational learning is a process through which organizations understand and manage their own experiences. Organizational learning is essentially knowledge production is concerned [22]. Today, Intellectual Asset Management organizations to more achievements in future competitive markets and a reliable credit will present era of intellectual capital as a stimulus vital for stability Yale has a reputation system transformation in today's competitive environment. Knowledge through organizational learning perspective to the organization, spread in all components of intellectual capital [3]. Organizational learning, organizational memory means should cause the storage, representation and sharing of knowledge and intellectual and human capital is providing. Intellectual capital management system that can learn new knowledge into improved management and control of the people [Garvin, 2000], Intellectual capital is a set of knowledge-based assets that are allocated to one of the most important characteristics of the through adding value to the organization's key stakeholders, to significantly improve the competitive position of leads [15].

Dimensions of intellectual capital are: human capital: human capital as individual knowledge, skills, abilities and experience of the employees of an organization to create value and solve problems defined by Further research into the human capital theorists who have considered it a personal level and it's a combination of knowledge, skill, and talent have ever seen capital structure capital structure refers to the structures and processes within an organization in which employees use them and thus are employing knowledge and skills. The funding mechanisms and structures, including the major role in supporting staff to achieve optimal performance and intellectual side of the business is functioning optimally. Poyning has a broad view of its economic relations with various stakeholders, especially potential customers are known. This form is in several directions, such as capital, intellectual capital, and is part of the basic values embedded in the marketing and communications channels through which organizations conduct their business [4].

Organizational learning is a continuous need for credible information, transparency, and assessment information is appropriate and responsive system. Organizational learning is influenced by individual learning and organizational members. Learning organizational change, innovation, technology development, production and profits are concerned, as well as internal organizational learning systems, personal values and attitude toward the organization is concerned. Learning organizations are usually flexible and quick to respond to new environmental challenges. Learning organization is an organization that all intellectual power, knowledge and experience of the organization to change and continuous improvement and further development of the handles. Learning organizations' ability to create, implement and apply their knowledge. Such capability is critical for companies to develop a sustainable competitive advantage [20]. Organizational learning, innovation and new knowledge give priority to the role of individuals in creating and applying new knowledge highlights. In the near future, the organization may be able to claim superiority capabilities, commitment and capacity to learn in "all" levels of the organization to operate efficiently. Organizational learning capability can be added to better adapt to their changing environment and to be more successful. Organizational learning is a critical source of competitive advantage in the field of strategic management is fundamental. Organization that is dynamic and changing environment involves not only efficient enough to process information, but also to generate knowledge and information. Williams (1992) found that all industries are facing dramatic changes, and these changes will flow through to customers and competitors, or is caused by the suppliers of technology. These changes are consistent pressure to create jobs, produce to improve customer retention. Therefore, learning faster than competitors makes it possible sustainability of competitive advantage [6]. In today's dynamic world economically successful organizational trust, organizational learning taken seriously as an organizational learning process to achieve the highest level of organizational effectiveness is easy. Drucker (1993) suggests that knowledge is not just a source of business advantage and starts rather exclusive and unique source of advantage for the organization. Dixie (1996) argues that learning is superior to other materials because it enables the company to process information at a faster rate through continuous improvement activities of the central competitive advantage to maintain for long periods [8]. First time in 1919 by Karl Erik term biotechnology to mean the use of Bioscience and Human-technology interaction that was used. Biotechnology such words are vocal in recent years. Biotechnology is the application of a general definition of organism or organisms or biological processes in manufacturing or service industries considered. The simple definition of novelty is the use of an integrated knowledge Biochemistry, Microbiology and bio-tech production systems due to the use of the interdisciplinary nature of science are studied. Another definition of biotechnology (biotech) has been described:

Technique of living organisms to make or modify products, improve plants or animals, and the qualitative characteristics of microorganisms used for special applications. Biotechnology is an interdisciplinary science due to its inherent features .engineering.

1. Genesis Biotechnology
2. Traditional uses of biotechnology
3. Products derived from biotechnology
4. Education in Iran
5. External links

The use of microorganisms to produce foods such as fruit,yogurt, and cheese dates back over eight thousand years ago. They did Louis Pasteur help. Louis Pasteur discovered that yeast alcohol turn to sugar in a vacuum. This process is called anaerobic fermentation. And that rancidity and contamination of those activities acetic acid bacteria that converts alcohol into vinegar happens. Traditional plant breeding and biotechnology applications including live stock,bread, yogurt and cheese are. Is then produced antibiotics (antibiotics) , human insulin and interferon Laboratory Medicine and now with the advent of recombinant DNA technology , genetic manipulation and gene transfer from one organism to another, or in other words , genetic engineering , capacity utilization this kind of technology is increasingly enhanced .application of modern biotechnology techniques are effective in increasing the production of milk and meat .

Population of over six billion inhabitants of the planet's health through the production of recombinant drugs and vaccines , low-cost access to treatment and diagnosis of diseases and find cure diseases faster and more effective treatment of various diseases including genetic diseases duties of medical biotechnology .Removal of hazardous environmental contaminants and filter microorganisms from the environment using the techniques of genetic resources, including biotechnology applications in the field of environment be remembered. Biotechnology also other ways to produce products that previously did not exist or it has been very difficult, is possible. Cullen (1999) has investigated the relationship between individual and organizational learning, Flood in1998 that examined how much and how systems thinking on interpersonal skills and motivation affect creates learning, interpersonal skills, organizational learning related to Thomas in 1994, has been measured [13].Kang believes that organizational learning occurs and the individual skills of these managers need to focus on the idea of a system that leads to improve organizational performance. Leonard in (1992)shows the importance of personal development and learning in the laboratory. Citizenship learning in small and medium sites was analyzed. Hurley and Hurt positive relationship between innovation and organizational learning (1998) have shown finally, in 2002, showed that avoids negative effects of innovation on organizational performance. [11],[12].Skills of the individual and the relationship between learning and innovation analyzed. The main objective of the training is to learn, to change the behavior of the labor force is applied, these changes will lead to improved skills and knowledge of the individual increases So that the worker is able to effectively and efficiently do their current job and are ready to take more responsibility for promoting the job always won. However, the effectiveness of the functioning of an organization is required to improve the skills of employees [16].Perky (1994) believes the lack of success of the learning, which is associated with the continuous development of employees and organizational learning, failed. He proposes to get ideas for creating a true learning organization, organizational learning and the role of organizational learning and the role of assessors in providing the re-introduction of and success of the learning organization in the improvement of human resources development specialists emphasized. Neefe (2001) investigated the role of education and knowledge-based enterprises, entrepreneurship and wealth- creating knowledge based economy in Europe has noted. He is an educational application for this role will require the use of ICT in teaching and it is concluded that the foundation of knowledge centers and companies can benefit from this technology effectively with learning organization requirements. Studies, Wang (2004) to determine the dimensions of the learning organization in the public hospitals of Hong Kong, officials attempt to create a shared vision among faculty and staff, educational goals, have a positive attitude toward the teaching staff of these centers are achieved. Shankar (2005), the U.S. intellectual capital and organizational performance variables studied, the results show that there is a relationship between variables moderate to low. Peter (2009) study entitled : Between 2009-2007 global economic crisis and its effect on the development of intellectual capital has done, which shows what must be determined is the extent of these effects : identifying the particular affected the stringencies of both groups reporting on intellectual capital based on an evaluation of the stock is very fleeting . Use of this intellectual capital in anticipation rather than questions of economic shocks and includes the conceptual and practical reasons. [17], [18], [13].

Hong (2010) study to examine the effects of social capitalstructural, human resource, knowledge production and its effects on the diversity of technical knowledge. The results are as follows: Firstly, it is proved that the intellectual capital is a phenomenon resulting from the relationship, and secondly, it is proved that knowledge diversity is a

phenomenon of moderation. Finally, all aspects of intellectual capital have a positive and significant impact on knowledge production is. Vera (2005) says that in the light of knowledge management and organizational learning in knowledge-based companies to raise their performance. Kong (2005) writes: Both researchers and managers to track how the mutual learning organizations are more interested in means to simultaneously explore new areas of knowledge and areas of current. To create a context for mutual learning methods of human resources should be considered, based on the composition of human capital, organizational and social impacts. George Claudio (2006), in which research: challenges facing organizations in a dynamic economy requires intangible assets to achieve competitive position in the market. The growing importance of intellectual capital has thrown a challenge to the traditional financial reporting system and other systems have shown that this is not information needs. Another study concluded that harden (2008) have been suggested: a new concept based on dynamic knowledge and an approach to the development of intellectual capital in an organization that has provided the knowledge to change the concept of intellectual capital will up. The model of intellectual capital through changes in attitude by the general areas of knowledge and its related parties acquired parts of their knowledge of changes in beneficial amended. Achieve the goal of knowledge and a new concept that dynamic is introduced. The concept of knowledge is presented as a cube, i.e., a three dimensional model of knowledge with types and quality varies. Following types of knowledge, including knowledge of the subject is demonstrated. [1], [16].

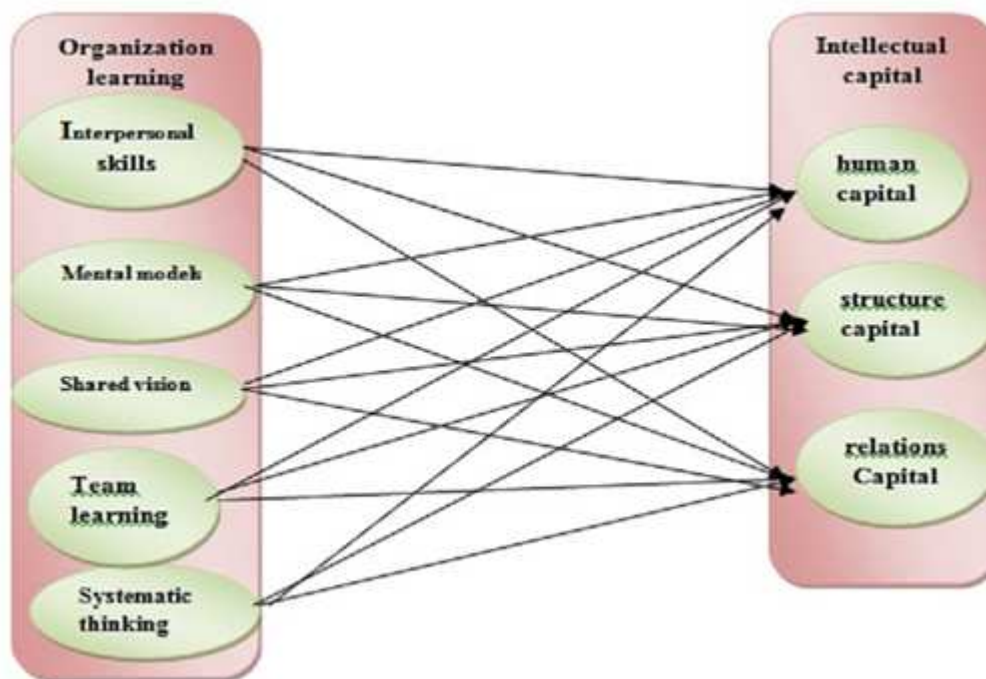

Theoretical framework of the research

In this paper, using the concepts of organizational learning and intellectual capital conceptual model has been developed. The relational model of organizational learning (interpersonal skills, mental models, shared vision, team learning, systems thinking), intellectual capital (human capital, structural capital, relational capital) review.

Hypotheses

- 1-Interpersonal skills can impact on human capital biotechnological production of Iranian companies.
- 2-Interpersonal skills affect the capital structure biotechnological production of Iranian companies.
- 3-Interpersonal skills of relational capital affect biotechnological production of Iranian companies.
- 4-Mental models of human capital affect biotechnological production of Iranian companies.
- 5-Mental models affect the capital structure biotechnological production of Iranian companies.
- 6-Mental models of the biotechnological production of Iranian companies to invest in a relationship.
- 7-Shared perspective on the biotechnological production of Iranian companies is human capital.
- 8-A common perspective on the capital structure of companies, biotech products are produced in Iran.
- 9-A shared vision of the biotechnological production of Iranian companies to invest in a relationship.
- 10-Learning Team has an effect on human capital biotechnological production of Iranian companies.
- 11-Learn the biotechnological production of Iranian companies is controlled by the structural funds.
- 12-The investor relations team learning is effective biotechnological production of Iranian companies.

13-After thinking, organizational learning system has effect on human capital biotechnological production of Iranian companies.

14- Systems thinking on capital structure have an impact on biotechnological production of Iranian companies.

15- Systems thinking is the capital of biotechnological products related to Iranian companies

MATERIALS AND METHODS

The method of this study is a causative one and in this way, the relationship between variables based on the target of this study was analyzed. Also this study based on the studies classification in terms of how to collect the data or in the other words, the design of this research, is a descriptive study which describes the properties of a sample and then generalizes these properties to the statistical society. These studies were classified into many groups but in this study, the measuring one is used. Through this study, the relationship between variables were described, predicted and analyzed. Therefore it can be said that the method of this study is descriptive – measuring and causative one and based on the defined target, it is a functional. The population studied in this research, all the staff and employees of companies that produce biotech-up in summer 1392 with a bachelor's degree, have been working to establish. Minimum sample size of 300 was determined using Cochran's formula. Questionnaire to collect data using standardized questionnaires Neefe organizational learning(2001) and standard questionnaires designed Bontis intellectual capital has been used.

RESULTS AND DISCUSSION

190 of the respondents was male and 90 are female. In order to analyze the data and test the hypothesis of structural equation modeling is used. Structural equation modeling such as linear statistical models to examine the relationship between latent variables (unobserved) variables and manifest (observed) is. Indicators of overall fitness as well as an index and CFI RMSEA are considered as the best indicator. Indicators of overall fitness placed in ranges between 0 and 1. Coefficients higher than 0/90 is considered to be acceptable, although the level, $P=0/05$, is optional. This calculated value for the RMSEA index is equal to 0/075 to index $CFI=0/95$, which is indicative of the acceptability of the research model.

Table1: parameters associated with the model presented Indicator of acceptable fit

Acceptable fit	Amount	Index
Value between 1 and 3	2/312	Chi-square relative
RMR < %5	0/026	RMR
GFI > %90	0/932	GFI
AGFI > %90	0/928	AGFI
RMSEA < %10	0/075	RMSEA
CFI > %90	0/95	CFI
IFI > %90	0/914	IFI
NFI > %90	0/963	NFI

With emphasis on the goodness of fit of the six models, the researchers suggest has the perfect fit. Therefore a good fit between the model and the structural model has been illustrated with experimental data are provided and can be a suitable model for the structure with a intellectual capital. Hence, the emphasis on structural equation model was designed to fit in the field of intellectual capital represents the best fit of structural equation modeling with emphasis on organizational learning and intellectual capital.

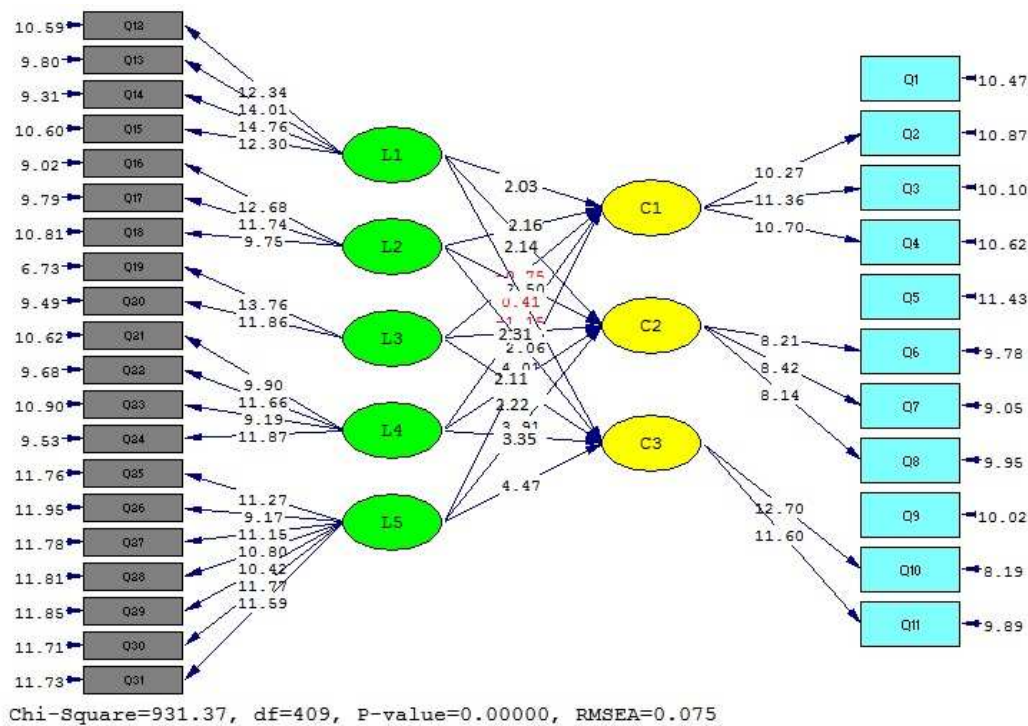

Figure 2 the t-statistic for each coefficient

In this section, we will model to determine the significance of the numbers, the numbers are significant, since this would be 0/95 or error 0/05, followed by hypothesis testing, we used t test, and significant numbers will be larger than 1/96 and 1/96are. This means that if the t -test and numerical 96/1- 96/1 + may be meaningless. The following model (Figure 1) are significant numbers obtained for the t -test can determine causal relationships (measured with latent variables) and effects (both latent variables) with respect to the items listed in the charts below, the model the fit parameters are in good condition. Summarizes the resultsof testing hypothesesinthefollowing table:

Table 2: Summarizes the results of testing hypotheses

results	T-statistics	Standardized Coefficients calculated	Assumptions
+	2/03	0/31	1 - Interpersonal skills can impact on human capital biotechnological production of Iranian companies.
+	2/16	0/23	2 - Interpersonal skills affect the capital structure biotechnological production of Iranian companies.
+	2/50	0/16	3 - Interpersonal skills of relational capital affect biotechnological production of Iranian companies.
+	2/14	0/32	4 - Mental models of human capital affect biotechnological production of Iranian companies.
-	0/41	0/27	5 - Mental models affect the capital structure biotechnological production of Iranian companies.
+	2/06	0/23	6 - Mental models of the biotechnological production of Iranian companies to invest in a relationship.
-	-1/75	0/31	7 - Shared perspective on the biotechnological production of Iranian companies is human capital.
+	2/31	0/29	8 - A common perspective on the capital structure of companies, biotech products are produced in Iran.
-	-1/16	0/43	9 - A shared vision of the biotechnological production of Iranian companies to invest in a relationship.
+	2/11	0/18	10 - Learning Team has an effect on human capital biotechnological production of Iranian companies.
+	4/02	0/41	11 - Learn the biotechnological production of Iranian companies is controlled by the structural funds.
+	3/31	0/28	12 - The investor relations team learning is effective biotechnological production of Iranian companies.
+	2/22	0/34	13 - After thinking, organizational learning system has an effect on human capital biotechnological production of Iranian companies.
+	3/35	0/33	14 - Systems thinking on capital structure have an impact on biotechnological production of Iranian companies.
+	4/47	0/32	15 - Systems thinking is the capital of biotechnological products related to Iranian companies

CONCLUSION

According to the study, three hypotheses were rejected and hypotheses were accepted. Mental models of capital structure do not affect the biotechnological production of Iranian companies. Shared vision on human capital does

not affect the biotechnological production of Iranian companies. Shared vision on relational capital does not affect the biotechnological production of Iranian companies. Based on organizational learning other aspects of the biotechnological production of Iranian companies have intellectual capital. Ahmed (2003) due to the significant role of organizational learning characteristics within the optimal use of information and communication technology has. Vera (2005) argues that in the light of knowledge management and organizational learning in knowledge-based companies to raise their performance. George Claudio (2006) the challenges facing organizations in a dynamic economy in the use of intangible assets and intellectual capital knows no utilization. Martinez (2009) suggests that the relational capital (customer) and there is a significant relationship between organizational performance. And also a significant positive relationship between capital structure and corporate performance exist. Felipa Lopez (2010) says: knowing the age of modern science and technology to identify vectors and four wood associated with organizational intellectual capital is essential According to a study. Since Regiment (2010) is consistent with all aspects of intellectual capital and knowledge based on organizational learning is positively related to that.

REFERENCES

- [1] Argyris, C. and Schon, D., **1996**, Organizational learning II: Theory, method and practice, Reading, Mass: Addison Wesley.
- [2] Argyris, c. & Schon, D. A. (**1996**). "Organizational learning: A Theory of Action perspective" , Addison-Wesley: Toward a unify theory of behavioral change. Psychological.
- [3] Bontis, nick, (**2004**), "Intellectual capital: An Explanatory study that Develops Measures and Models: management decision, 36/2: pp:63-76.
- [4] Bounfour, Ahmed, (**2003**), "The IC-dVAL Approach", journal of Intellectual capital, 4/3:396-412.
- [5] Cangelosi, V. E. , & Dill, W. R. (**1965**) " Organizational learning: observations toward a theory, " Administrative science quarterly.
- [6] Conger j. A., and Kanungo, R. n **1988**. " the empowerment process." Academy of management.
- [7] Dodgson, M. , (**1993**) "organizational learning: A Review of some literature", organization studies, Academy of management.
- [8] Daft, Richard l. (**1998**). "Essentials of organizational theory and Design." Cincinnati: south , Harvard Business Review.
- [9] Dusya, Vera , **2005**, "Organization Learning, Knowledge Management and Intellectual Capital :AN Integrative Conceptual Model". In P.C Nystrom and W.H Starboock (Eds), Handbook of Organizational Design:3-27. Oxford England. Oxford university Press.
- [10] Garvin, D. A., **2000**, Learning in Action. A guide to putting the learning organization to work, Boston, Mass: Harvard Business School Press.
- [11] Greoge, Claudiu, **2006**, *Strategic Management Journal*, 15, 53-61.
- [12] Hanvaisch, S., Sivakumar, K., Tomas, G., **2006**, *Journal of the Academy of marketing science*, vol, 34 No. 4.
- [13] Kang, S. C, Morris, S. S, and Snell, S. A., **2007**, *Academy of management review* , vol.32 No. 1.
- [14] Lopes dos, Felipa, **2010**, "the Model of Intellectual Capital Approach on the Human Capital Vision", [Dissertation Abstract Ed. D] Open university of Portugal.
- [15] Marr, Bernard and Giovanni Schiuma, (**2001**), "Measuring and Managing Intellectual Capital and Knowledge Assets in New Economy Organizations .", in M. Bourne (ed), Handbook of Performance Measurement. London: Gee publishing Ltd.
- [16] Martines, Isabele, **2009**, the Importance of Intellectual Capital in Organization", [Dissertation Abstract PH.D] university of Glomorgan Business School, Pontypridd UK.
- [17] Neefe, Diane Osterhaus (**2001**). Comparing Levels of Organizational Learning Maturity Colleges And Universities Participating Traditional & Non-traditional (Academic Quality Improvement Project) Accreditation Processes.
- [18] Persikll, **1994**, "How Organization Learning Occurs Through Academic Quality Improvement Program (AQIP), Action project: A Community College experience, [Dissertation Abstract Ed. D] University of Ilinis at ur-bana-champaing.
- [19] Shankar, Ravi; Gupta, Amol (**2005**), *Knowledge and Process Management*, Vol. 12, Issue 4, PP 259-277.
- [20] Stwart, Thomas. A, (**2006**) "Intellectual capital: the new wealth of organization", New york, NY. Doubleday, currency.
- [Kang, 2005] Sung-Choon- Kang, **2005**, "Intellectual Capital Architectures and Bilateral Learning: A Framework for Human Resource Management", Center for Advanced Human Resource Studies Cornell university of New York.
- [22] Yi-Chun-Hang, **2009**, *Strategic Management Journal*, 20, 637-653. Zack, M.