

Effect of body acceleration on pulsatile blood flow through a catheterized artery

Varun Kumar Tanwar¹, N. K. Varshney¹ and Raja Agarwal²

¹Department of Mathematics, S. V. College, Aligarh, (India)

²Department of Mathematics, Accurate Institute of Management & Technology, Gr. Noida, (India)

ABSTRACT

A mathematical model has been developed for studying the effect of body acceleration on pulsatile blood flow through a catheterized artery with an axially non-symmetrical mild stenosis. The blood is assumed to be Newtonian fluid. Perturbation method is used to solve the resulting system of non-linear partial differential equation with appropriate boundary condition to investigate the flow. Analytical expressions for velocity profile, volumetric flow rate, wall shear stress and effective viscosity have been obtained. The computational results are presented graphically. It is noticed that the axial velocity increases as the body acceleration increases and the axial velocity decreases as the phase angle of body acceleration increases.

Keywords: Body acceleration, Catheterized artery, Newtonian fluid,

INTRODUCTION

The theoretical analyses of blood flow are very useful for the diagnosis of a number of cardio vascular diseases and development of pathological patterns in human physiology. The use of catheters is of immense importance and has become standard tool for diagnosis and treatment in modern medicine. It flows as a Newtonian fluid, with shear stress being linearly related to rate of shear strain. If the stenosis is present in an artery, normal blood flow is disturbed and body acceleration changed the blood velocity significantly. The velocity of blood under the pumping action of the heart is increased at the high amplitude of body acceleration.

It is important to analyze the effect of periodic body acceleration on different part of body. Prolonged exposure of a healthy human body to external acceleration may cause serious health problem like headache, loss of vision, abdominal pain, and increase pulse rate. Due to physiological importance of body acceleration, many researchers have been proposed for blood flow with body acceleration. Agarwal and Varshney [1] considered MHD pulsatile flow of couple stress fluid through an inclined circular tube with periodic body acceleration. Biswas and Chakraborty [2] investigated pulsatile blood flow through a catheterized artery with an axially non symmetrical stenosis. Biswas and Chakraborty [3] discussed pulsatile Flow of Blood in a Constricted Artery with Body Acceleration. Chaturani and Biswas [4] studied a comparative study of Poiseuille flow of a polar fluid under various boundary conditions with applications to blood flow. Day [5] discussed the no-slip condition of fluid dynamics. Daripa and Dash [6] studied a numerical study of pulsatile blood flow in an eccentric artery using a fast algorithm. Dash and Jayaraman [7] investigated estimation of increased flow resistance in a narrow catheterized artery- A theoretical modal .Jayaraman and Dash [8] investigated numerical study of flow in a constricted curved annulus: An application to flow in a catheterized artery. Karahalios [9] discussed some possible effects of a catheter on the

arterial wall. McDonald [10] studied pulsatile flow in a catheterized artery. McDonald [11] investigated on Steady Flow through Modeled Vascular Stenosis. Misra and Shit [12] studied role of slip velocity in blood flow through stenosed arteries: A non-Newtonian model. Nagarani and Sarojamma [13] discussed effect of body acceleration on pulsatile flow of Casson fluid through a mild stenosed artery. Ponalgusamy [14] studied blood flow through an artery with mild stenosis: A two-layered model, different shapes of stenoses and slip velocity at the wall. Sankar and Lee [15] investigated mathematical modeling of pulsatile flow of non-Newtonian fluid in stenosed arteries. Sankar and Hemalatha [17] studied a non-Newtonian fluid flow model for blood flow through a catheterized artery steady flow. Taylor [18] investigated the influence of anomalous viscosity of blood upon its oscillatory flow. Young [19] discussed fluid mechanics of arterial Stenosis .Young [20] studied effects of a time-dependent stenosis of flow through a tube.

In the present section we have considered the problem of Biswas *et al* [2] by introducing body acceleration effect under the same conditions taken by Biswas *et al* [2].

The effect of body acceleration on pulsatile blood flow through a catheterized artery subject to a slip velocity condition at the constricted wall is investigated. Analytical expressions for axial velocity and volumetric flow rate, wall shear stress and effective viscosity have been derived and the effects of various parameters on these flow variables have been studied.

Mathematical model

Consider an axially symmetric, laminar, pulsatile and fully developed flow of blood through a catheterized artery with mild stenosis. It is assumed that the stenosis develops in the arterial wall in an axially non-symmetric but radially symmetric manner and depends upon the axial distance z as shown in Fig. 1. It is assumed that blood is represented by a Newtonian fluid.

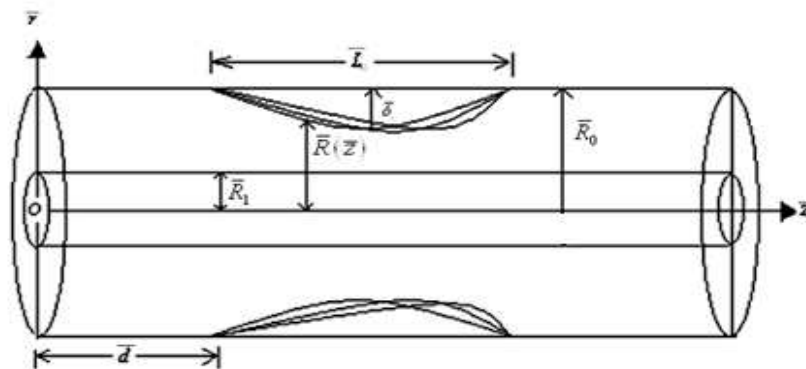

Figure.1.Geometry of an axially non-symmetrical stenosis with an inserted Catheter

The geometry of the stenosis [14] is given by

$$\bar{R}(\bar{z}) = \begin{cases} \bar{R}_0 - \bar{A} \left[\bar{L}_0^{n-1} (\bar{z} - \bar{d}) - (\bar{z} - \bar{d})^n \right]; & \bar{d} \leq \bar{z} \leq \bar{d} + \bar{L}_0 \\ \bar{R}_0; & \text{otherwise} \end{cases} \dots\dots(1)$$

where $\bar{R}(\bar{z})$ is the radius of the artery in the stenosed region, \bar{L}_0 is stenosis length, \bar{R}_0 is the radius of the normal artery, \bar{d} indicates its location and $n \geq 2$ is a parameter (called shape parameter) determining the stenosis shape (the symmetric stenosis occurs when $n = 2$).

The parameter \bar{A} is given by $\bar{A} = \frac{\bar{\delta} n^{\frac{n}{n-1}}}{\bar{L}_0(n-1)}$ where $\bar{\delta}$ denotes the maximum height of the stenosis located

$\bar{z} = d + \bar{L}_0 / n^{\frac{n}{n-1}}$ such as $\bar{\delta} / R \ll 1$. It has been reported that the radial velocity is negligibly small and can be neglected for a low Reynolds number flow in a tube with mild stenosis.

The equations of motion governing the fluid flow are given by

$$\bar{\rho} \frac{\partial \bar{u}}{\partial \bar{t}} = -\frac{\partial \bar{p}}{\partial \bar{z}} - \frac{1}{r} \frac{\partial}{\partial \bar{r}} (\bar{r} \bar{\tau}) + G(\bar{t}) \tag{2}$$

$$\frac{\partial \bar{p}}{\partial \bar{r}} = 0 \tag{3}$$

where \bar{u} is the fluid velocity in the axial direction, $\bar{\rho}$ is the density and \bar{p} is the pressure. The constitutive equation

of Newtonian fluid is given by $\bar{\tau} = -\mu \frac{\partial \bar{u}}{\partial \bar{r}}$ (4)

where μ is the coefficient of viscosity and $\bar{\tau}$ is the shear stress. The boundary conditions are given by

$$\bar{u} = \bar{u}_s \text{ at } \bar{r} = \bar{R}(\bar{z}) \tag{5}$$

$$\bar{u} = 0 \text{ at } \bar{r} = \bar{R}_1 \tag{6}$$

where \bar{u}_s is the slip velocity at the stenotic wall and $R_1 (\ll R_0)$ is the radius of the catheter. Since, the pressure gradient is a function of \bar{z} and \bar{t} , we take

$$-\frac{\partial \bar{p}}{\partial \bar{z}}(\bar{z}, \bar{t}) = q(\bar{z}) f(\bar{t}) \tag{7}$$

where $\bar{q}(\bar{z}) = -\frac{\partial \bar{p}}{\partial \bar{z}}(\bar{z}, 0)$, $f(\bar{t}) = 1 + a \sin \bar{\omega}_p \bar{t}$ and $G(\bar{t}) = a_0 \cos(\bar{\omega}_b \bar{t} + \phi)$ where a is the amplitude of blood flow and $\bar{\omega}_p$ is the angular frequency of blood flow. $\bar{\omega}_b$ is the angular frequency of body acceleration, a_0 is the amplitude of body acceleration, ϕ is the phase angle of body acceleration, \bar{p} is the pressure gradient and \bar{t} is time. Let us introduce the following non-dimensional variables

$$\begin{aligned} z &= \frac{\bar{z}}{R_0}, \quad R(z) = \frac{\bar{R}(\bar{z})}{R_0}, \quad R_1 = \frac{\bar{R}_1}{R_0}, \quad r_1 = \frac{\bar{r}}{R_0}, \quad t = \bar{t} \bar{\omega}, \quad L_0 = \frac{\bar{L}_l}{R_0}, \\ d_0 &= \frac{\bar{d}}{R_0}, \quad \delta = \frac{\bar{\delta}}{R_0}, \quad A = \bar{A} \bar{R}_0^{n-1}, \quad u = \frac{\bar{u}}{\bar{q}_0 \bar{R}_0^2 / 4 \bar{\mu}}, \quad \omega = \frac{\bar{\omega}_b}{\bar{\omega}_p}, \quad B = \frac{a_0}{\bar{q}_0}, \dots \tag{8} \\ u_s &= \frac{\bar{u}_s}{\bar{q}_0 \bar{R}_0^2 / 4 \bar{\mu}}, \quad \alpha^2 = \frac{\bar{R}_0^2 \bar{\omega} \bar{\rho}}{\bar{\mu}}, \quad \tau = \frac{\bar{\tau}}{\bar{q}_0 \bar{R}_0}, \quad q(z) = \frac{\bar{q}(\bar{z})}{\bar{q}_0}, \end{aligned}$$

Where α is the pulsatile Reynolds numbers for Newtonian fluid and \bar{q}_0 is the negative of the constant pressure gradient in a uniform tube without catheter. The non-dimensional form of geometry of stenosis is given by

$$\bar{R}(\bar{z}) = \begin{cases} 1 - A \left[L_0^{n-1} (z-d) - (z-d)^n \right]; & d \leq z \leq d + L_0 \\ 1; & \text{otherwise} \end{cases} \quad \dots\dots (9)$$

Using non-dimensional variables equations (2) and (4) reduce to

$$\alpha^2 \frac{\partial u}{\partial t} = 4 \left[q(z) f(t) + G(t) \right] - \frac{2}{r} \frac{\partial}{\partial r} (r\tau) \quad \dots\dots (10)$$

$$\tau = -\frac{1}{2} \frac{\partial u}{\partial r} \quad \dots\dots (11)$$

With the help of (11), equation (10) becomes

$$\alpha^2 \frac{\partial u}{\partial t} = 4 \left[q(z) f(t) + G(t) \right] + \frac{1}{r} \frac{\partial}{\partial r} \left(r \frac{\partial u}{\partial r} \right) \quad \dots\dots (12)$$

The boundary conditions in the non-dimensional form are given by

$$u = u_s \text{ at } r = R(z) \quad \dots\dots (13)$$

$$u = 0 \text{ at } r = R_1 \quad \dots\dots(14)$$

Method of solution

Considering the Womersley parameter to be small, the velocity u can be expressed in the following form

$$u(z, r, t) = u_0(z, r, t) + \alpha^2 u_1(z, r, t) + \dots\dots\dots \quad \dots\dots(15)$$

Substituting the expression of u from equation (15) in (12), we have

$$\frac{\partial}{\partial r} \left(r \frac{\partial u_0}{\partial r} \right) = -4 \left[q(z) f(t) + G(t) \right] \quad \dots\dots(16)$$

$$\frac{\partial u_0}{\partial t} = \frac{1}{r} \frac{\partial}{\partial r} \left(r \frac{\partial u_1}{\partial r} \right) \quad \dots\dots(17)$$

Substituting u from equation (15) into conditions (13) and (14) we get

$$u_0 = u_s, u_1 = 0 \text{ at } r = R(z) \text{ and } u_0 = 0, u_1 = 0 \text{ at } r = R_1 \quad \dots\dots (18)$$

To determine u_0 we integrate equations (16) twice with respect to r and use the boundary conditions (18) we have

$$u_0 = \left[1 - \frac{\log\left(\frac{r}{R}\right)}{\log\left(\frac{R_1}{R}\right)} \right] u_s + [q(z)f(t) + G(t)] \left[(R^2 - r^2) - \frac{(R^2 - r^2)}{\log\left(\frac{R_1}{R}\right)} \log\left(\frac{r}{R}\right) \right] \dots\dots(19)$$

To determine u_1 , we integrate equations (17) twice with respect to r and use the boundary conditions (18) we have

$$u_1 = \frac{[q(z)f'(t) + G'(t)]}{16} \left[(4R^2r^2 - r^4 - 3R^4) - \frac{(R^2 - R_1^2)}{\log\left(\frac{R_1}{R}\right)} \left\{ 4r^2 \log\left(\frac{r}{R}\right) - 3r^2 + 3R^2 \right\} \right. \\ \left. - \frac{\log\left(\frac{r}{R}\right)}{\log\left(\frac{R_1}{R}\right)} \left\{ 4R^2R_1^2 - R_1^4 - 3R^4 - \frac{(R^2 - R_1^2)}{\log\left(\frac{R_1}{R}\right)} \left(4R_1^2 \log\left(\frac{R_1}{R}\right) + 3R^2 - 3R_1^2 \right) \right\} \right] \dots\dots(20)$$

Using the equation for axial velocity u can easily be obtained from equations (15), (19) and (20) are

$$u = \left[1 - \frac{\log\left(\frac{r}{R}\right)}{\log\left(\frac{R_1}{R}\right)} \right] u_s + [q(z)f(t) + G(t)] \left[(R^2 - r^2) - \frac{(R^2 - r^2)}{\log\left(\frac{R_1}{R}\right)} \log\left(\frac{r}{R}\right) \right] \\ + \alpha^2 \left[\frac{[q(z)f'(t) + G'(t)]}{16} \left[(4R^2r^2 - r^4 - 3R^4) - \frac{(R^2 - R_1^2)}{\log\left(\frac{R_1}{R}\right)} \left\{ 4r^2 \log\left(\frac{r}{R}\right) - 3r^2 + 3R^2 \right\} \right. \right. \\ \left. \left. - \frac{\log\left(\frac{r}{R}\right)}{\log\left(\frac{R_1}{R}\right)} \left\{ 4R^2R_1^2 - R_1^4 - 3R^4 - \frac{(R^2 - R_1^2)}{\log\left(\frac{R_1}{R}\right)} \left(4R_1^2 \log\left(\frac{R_1}{R}\right) + 3R^2 - 3R_1^2 \right) \right\} \right] \right] \dots\dots(21)$$

The wall shear stress τ_w (as a result of equations (11) and (18)) becomes

$$\tau_w = -\frac{1}{2} \left(\frac{\partial u_0}{\partial r} + \alpha^2 \frac{\partial u_1}{\partial r} \right)_{r=R(z)} \dots\dots(22)$$

which is determined, by substituting velocity expressions (19) and (20) into the above equation (22), in the form

$$\tau_w = \frac{u_s}{2R \log\left(\frac{R_1}{R}\right)} + [q(z)f(t) + G(t)] \left\{ R + \frac{(R^2 - R_1^2)}{2 \log\left(\frac{R_1}{R}\right)} \right\}$$

$$- \frac{\alpha^2}{32} [q(z)f'(t) + G'(t)] \left[4R^3 + 2R \frac{(R^2 - R_1^2)}{\log\left(\frac{R_1}{R}\right)} - \frac{1}{R \log\left(\frac{R_1}{R}\right)} \right]$$

$$\left\{ 4R^2 R_1^2 - R_1^4 - 3R^4 - \frac{(R^2 - R_1^2)}{R \log\left(\frac{R_1}{R}\right)} \left(4R_1^2 \log\left(\frac{R_1}{R}\right) + 3R^2 - 3R_1^2 \right) \right\} \dots\dots(23)$$

The non-dimensional volumetric flow rate is given by

$$Q = 4 \int_{R_1}^{R(z)} r u(r, z, t) dr \dots\dots(24)$$

Where $Q(t) = \frac{\bar{Q}(t)}{\pi(\bar{R}_0)^n}$, $\bar{Q}(\bar{t}) = 2\pi \int_{R_1}^{R(z)} \bar{r} \bar{u}(\bar{r}, \bar{z}, \bar{t}) d\bar{r}$
 $\frac{8\bar{\mu}}$

Using the equation (24) and (21), the expression for volumetric flow rate is given by

$$Q(t) = \left[2(R^2 - R_1^2) + \frac{2R_1^2 \log\left(\frac{R_1}{R}\right) - (R^2 - R_1^2)}{\log\left(\frac{R_1}{R}\right)} \right] u_s + [q(z)f(t) + G(t)]$$

$$\left[(R^2 - R_1^2)^2 - \frac{(R^2 - R_1^2)}{\log\left(\frac{R_1}{R}\right)} \left\{ \left(R_1^2 - 2R_1^2 \log\left(\frac{R_1}{R}\right) - R^2 \right) \right\} \right]$$

$$\begin{aligned}
 & + \frac{\alpha^2}{48} [q(z)f'(t) + G(t)] \left[\{18R^4R_1^2 + 2R_1^6 - 12R^2R_1^4 - 8R^6\} \right] - \\
 & \frac{(R^2 - R_1^2)}{\log\left(\frac{R_1}{R}\right)} \left\{ 6R^4 - 12R_1^4 \log\left(\frac{R_1}{R}\right) + 12R_1^4 - 18R_1^2 \right\} + \dots\dots(25) \\
 & \left[6R_1^2 + \frac{3(R^2 - R_1^2)}{\log\left(\frac{R_1}{R}\right)} \right] \left\{ 4R^2R_1^2 - R_1^4 - 3R^4 - \frac{(R^2 - R_1^2)}{\log\left(\frac{R_1}{R}\right)} \left\{ 24R_1^2 \log\left(\frac{R_1}{R}\right) + 18(R^2 - R_1^2) \right\} \right\}
 \end{aligned}$$

The effective viscosity μ_e defined by

$$\bar{\mu}_e = \frac{\pi \left(-\frac{\partial \bar{p}}{\partial \bar{z}} \right) (\bar{R}(\bar{z}))^4}{\bar{Q}(\bar{t})} \dots\dots(26)$$

can be expressed in dimensionless form as

$$\mu_e = \frac{(R(z))^4}{Q(t)} [q(z)f(t) + G(t)] \dots\dots(27)$$

The effective viscosity can be obtained with the help of the equation (27) and (25). If steady flow is considered, then equation (27) reduces to

$$\begin{aligned}
 Q_s = & \left[2(R^2 - R_1^2) + \frac{2R_1^2 \log\left(\frac{R_1}{R}\right) - (R^2 - R_1^2)}{\log\left(\frac{R_1}{R}\right)} \right] u_s + q(z) \left[(R^2 - R_1^2)^2 - \frac{(R^2 - R_1^2)}{\log\left(\frac{R_1}{R}\right)} \right. \\
 & \left. \left\{ R_1^2 - 2R_1^2 \log\left(\frac{R_1}{R}\right) - R^2 \right\} \right] \dots\dots(28)
 \end{aligned}$$

where Q_s is the steady state flow rate. Taking $Q_s = 1$ the value of $q(z)$ can be obtained from equation (28). In absence of catheter, (i.e. when $R_1 = 0$) the equation (19), (20), (23), (25) reduce to

$$u_0 = u_s + [q(z)f(t) + G(t)](R^2 - r^2) \dots\dots(29)$$

$$u_1 = \frac{[q(z)f'(t) + G'(t)]}{16} (4R^2r^2 - r^4 - 3R^4) \dots\dots(30)$$

$$\tau_w = [q(z)f(t) + G(t)]R - \frac{a^2}{8}[q(z)f'(t) + G'(t)]R^3 \dots\dots(31)$$

$$Q(t) = (R(z))^2 \left\{ 2u_s + [q(z)f(t) + G(t)](R(z))^2 - \frac{\alpha^2}{6}[q(z)f'(t) + G'(t)](R(z))^4 \right\} \dots\dots(32)$$

PARTICULAR CASE

If B is equal to zero then results agree with Biswas and Chakraborty [2], (2010).

RESULTS AND DISCUSSION

The velocity profile for the pulsatile blood flow through a catheterized artery with periodic body acceleration is computed by using (21) for different values of parameter time *t*, body acceleration parameter *B*, phase angle of body acceleration ϕ , and effects of stenosis height δ with slip velocity have been shown through figures 2 -5. The value 0.5 is taken for the amplitude *a* and the pulsatile Reynolds' number α , the range 0-0.2 is taken for the height of the stenosis δ . Radius of the catheter is taken in the range 0-0.5 and the value of the stenosis shape parameter is taken from 2 to 6. Figure - 2 shows that the variation of a axial velocity profile with radial distance *r* for different time periods *t*. It can be noted here that the axial velocity increases rapidly with time as *t* goes from $t = 0^0$ to $t = 135^0$ and then decreases sharply when *t* goes from $t = 180^0$ to $t = 315^0$. It can be clearly observed that as the body acceleration increases, the axial velocity profile increases (Figure -3). It can be noted here that the axial velocity decreases as the phase angle of body acceleration ϕ increases (figure-4). From figure-5, the axial velocity decreases with increase of stenosis height, for different slip velocity. It can be noted here that the magnitude of axial velocity is higher in a uniform artery than that in a stenosed artery. Also the axial velocity increases with the increase of slip velocity in both uniform and stenosed artery. The effective viscosity for the pulsatile blood flow through a catheterized artery is computed by using (27), the effects of stenosis height δ with slip velocity and for different values of shape parameter *n* have been shown through figures 6 -7. It can be clearly observed that as height of the stenosis δ increases, the effective viscosity increases (Figure - 6). It is found that effective viscosity increases with the catheter radius significantly increase but decreases with the shape parameter with slip velocity.

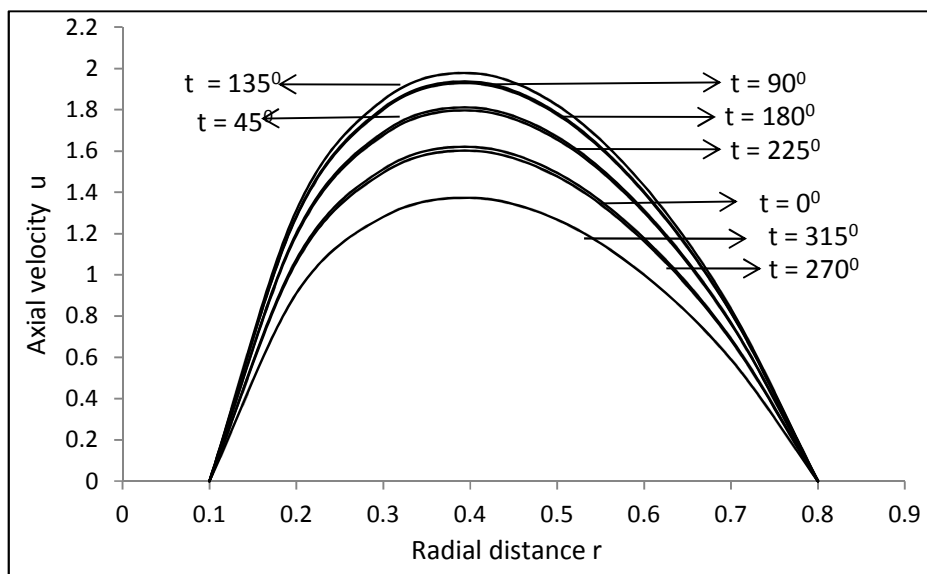

Figure 2: Variation of axial velocity with radial distance *r* for different *t*, with $R = 0.8, R_1 = 0.1, \alpha = 0.5, \phi = 0.5, a = 0.5$

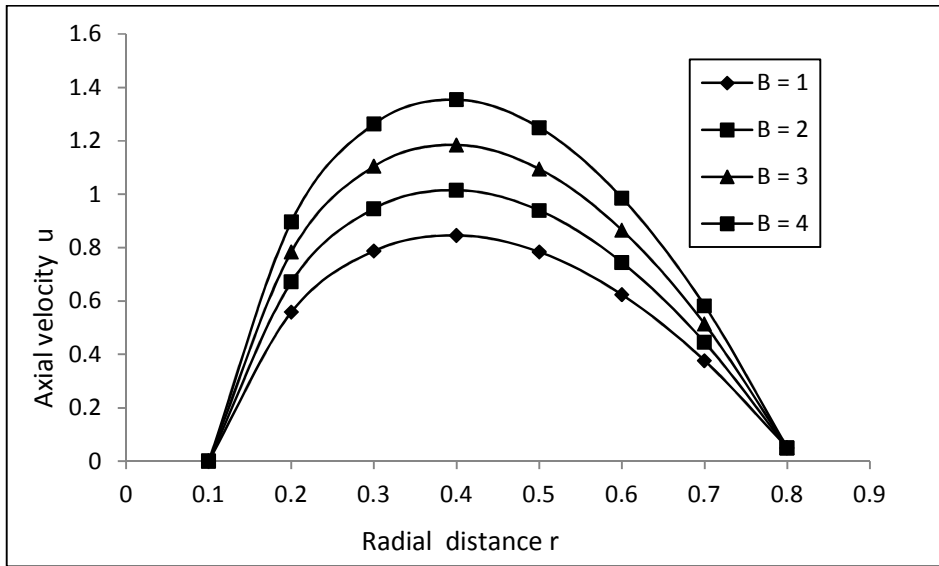

Figure 3: Variation of axial velocity with radial distance r for different B , with $R = 0.8$, $R_i = 0.1$, $\alpha = 0.5$, $\phi = 0.5$, $a = 0.5$

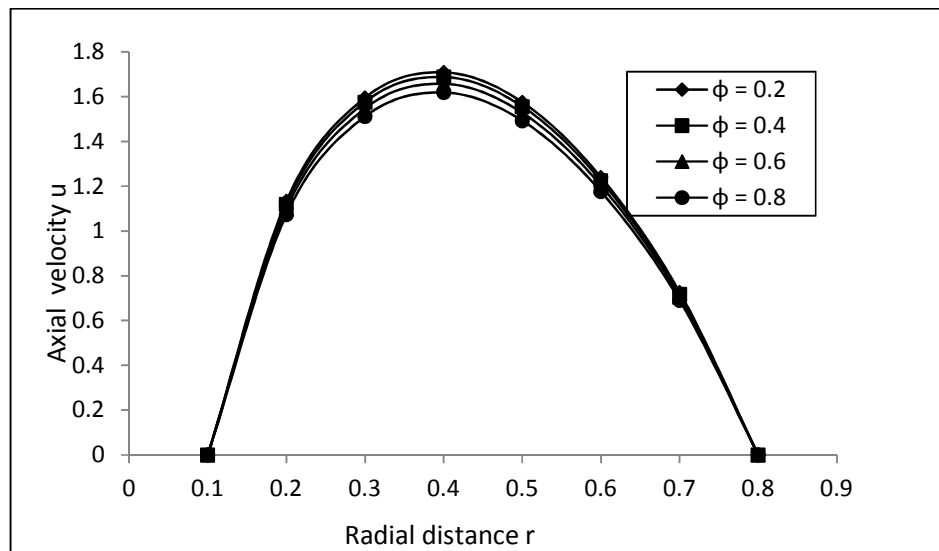

Figure 4: Variation of axial velocity with radial distance r for different ϕ , with $R = 0.8$, $R_i = 0.1$, $\alpha = 0.5$, $\phi = 0.5$, $a = 0.5$

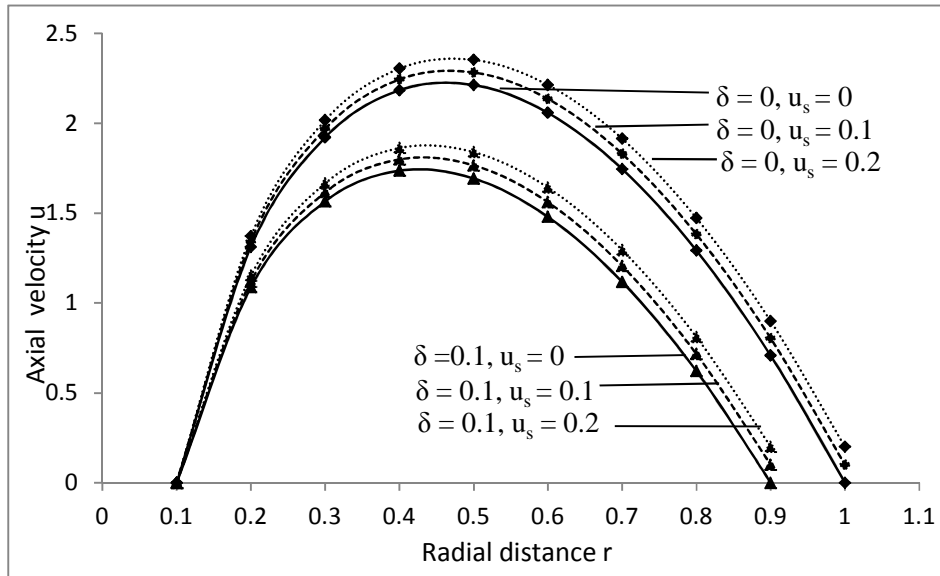

Figure 5: Variation of axial velocity with radial distance r for different δ , with $R = 0.8$, $R_1 = 0.1$, $\alpha = 0.5$, $\phi = 0.5$, $a = 0.5$

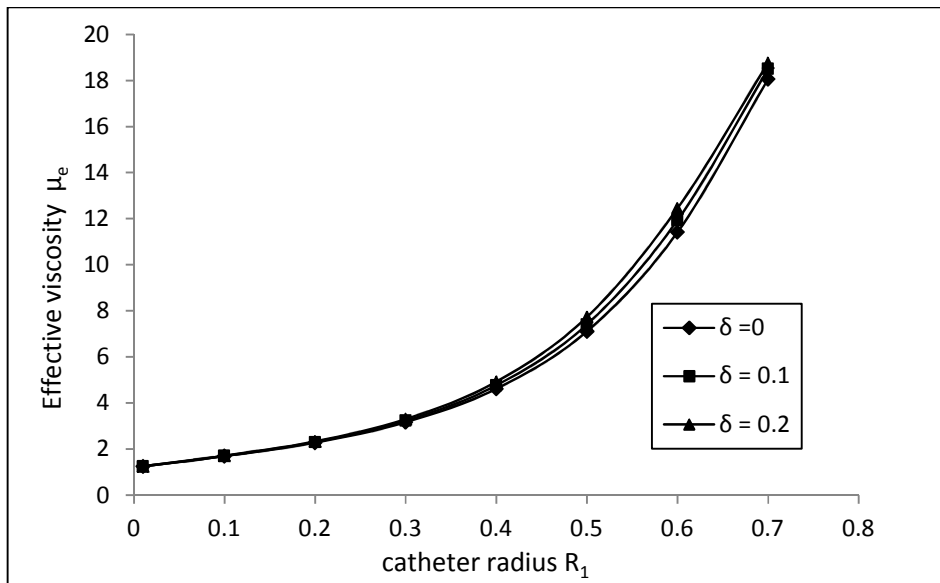

Figure 6: Variation of effective viscosity with catheter radius R_1 for different δ , with $R = 0.8$, $\alpha = 0.5$, $\phi = 0.5$, $a = 0.5$, $u_s = 0.05$

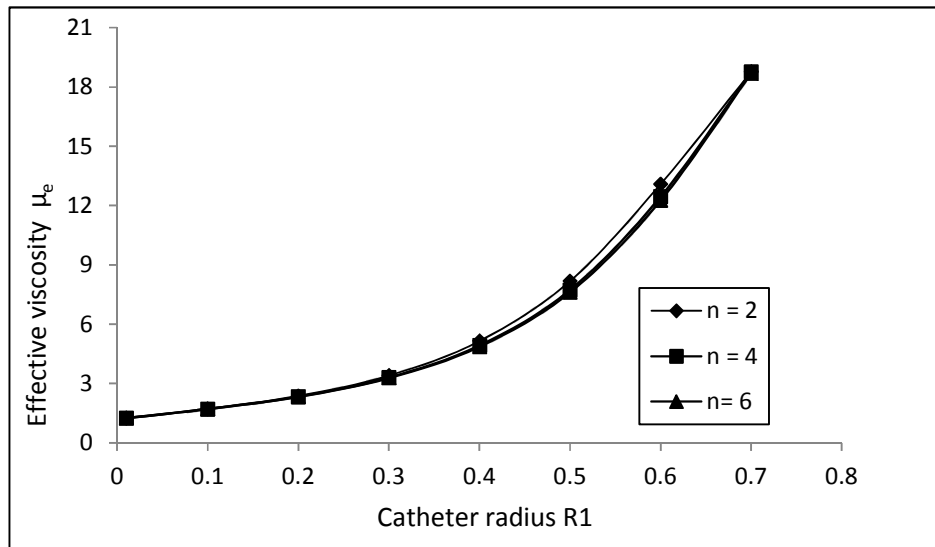

Figure 7: Variation of effective viscosity with catheter radius R_1 for different n , with $R = 0.8$, $\alpha = 0.5$, $\phi = 0.5$, $a = 0.5$, $u_3 = 0.05$

CONCLUSION

The present study deals with a theoretical investigation of body acceleration on pulsatile blood flow through a catheterized artery. Blood is represented as Newtonian fluid. Using appropriate boundary conditions, analytical expressions for the velocity profile, volumetric flow rate, wall shear stress, and effective viscosity have been obtained. It is clear from the above result and discussions that the body acceleration effects largely on the axial velocity of blood flow. In some situations the human body is subject to body accelerations, when vibration therapy is applied to a patient with heart disease, during flying in a spacecraft or sudden movement of the body during sports activities etc. Though human body has the natural capacity to adapt the changes, but prolonged exposure to such variations may lead to some serious health problems like abdominal pain, increase in pulse rate, and hemorrhage in the face, neck, lungs and brain etc.

Hence from all the above discussions we can conclude that a careful choice of the values of the parameters of body acceleration, yield stress will affect the flow characteristics and hence can be utilised for medical and engineering applications.

REFERENCES

- [1] Agarwal R, Varshney N.K, *Jour. PAS (mathematical Science)*, **2011**, Vol.17, 277-293.
- [2] Biswas D, Chakraborty U S, *Applied mathematical sciences*, **2010**, 4(58), 2865-2880.
- [3] Biswas D, Chakraborty U S, *Appl. Math.*, **2009**, 4, 329-342.
- [4] Chaturani P, Biswas D, *Rheol. Acta.*, **2011**, 23, 435-445.
- [5] Day M. A, *Erkenntnis*, **1990**, 33, 285-296.
- [6] Daripa P, Dash R K, *J. Eng. Math.*, **2002**, 42,1-22.
- [7] Dash R K, Jayaraman G, Mehta, K., *Journal of Biomechanics*, **1996**, 29(7), 917-930.
- [8] Jayaraman G, Dash, R K, *J. Eng. Math.*, **2001**, 40, 355-376.
- [9] Karahalios G T, *Med. Phys.*, **1990**, 17, 925-992.
- [10] McDonald D A, *J. Biomech.*, **1986**, 19, 239-249.
- [11] Mc Donald D A, *Journal of Biomechanics*, **1979**, 12(1), 13-20.
- [12] Mishra J C, Shit G C, *Journal of Mechanics in Medicine and Biology*, **2007**, 7 337-353.
- [13] Nagarani P, Sarojamma G, *Korea-Australia Rheology Journal*, **2008**, 20,189-196.
- [14] Ponalgusamy R, *Journal of Applied Sciences*, **2007**, 71071-1077.
- [15] Sankar D S, Lee U, *Comm. Nonlinear Sci. Numer. Simulat.*, **2009**, 14,2971-2981.
- [16] Sankar D S, Hemalatha K, *Applied Mathematical Modeling*, **2007**, 31,1847 -1864.
- [17] Sankar D S, *International Journal of Non-Linear Mechanics*, **2009**, 44, 337 -351.
- [18] Taylor M G, *Physics in Medicine and Biology*, **1959**, 3, 273-290.

- [19] Young D F, *J. Eng. Ind. Trans. ASME*, **1979**, 101, 157- 175.
[20] Young D F, *Journal of Eng. Ind.*, **1968**, 90, 248-254.