

Design and implementation of a filter for low-noise applications

^{1*}Ochala, I., ²Gbaorun, F and ¹Okeme, I. C

¹Department of Physics, Kogi State University, Anyigba

²Department of Physics, Benue State University, Makurdi

ABSTRACT

In this paper, we present the design and implementation of a filter for low-noise applications. The filter was designed using the methods of impedance and frequency scaling. It was built around a general-purpose operational amplifier ($\mu 741$) as the only active component with a centre frequency of 200Hz, a centre frequency gain of 16.00, a quality factor of 3.9, a bandwidth of 52Hz and a noise figure of 2.00. Specifically, it has been designed as a first stage in a low-noise amplifier (LNA) to be used for the measurement of atmospheric electric field.

INTRODUCTION

Man's quest for mastery of his universe has prompted him to explore natural phenomena around him with the intent to promote his comfort. This has taken the human society through various stages of development to this electronic age of explosive development in all ramifications. Developments in technology have resulted in the fabrication of a wide range of electronic devices covering a vast spectrum of applications. These devices, among others, are filters, amplifiers and oscillators. These have, over the years, enhanced industrialization, improved communication and bettered the lot of man a great deal.

The operation of filters is so cardinal that almost all electronic systems have one form of filter or another embedded in them. In electronic systems, noise, distortion and interferences are a great bother, because they affect free flow of signals deleteriously. The way to tackle this menace is to employ filters. Filters have special ability to separate desired signals from undesired signals, blocking interfering signals and enhancing signal strength in electronic systems.

Generally, filters have applications in Communications, RADAR, Consumer Electronics, Medicine, Industries, Security equipment, space vehicles and space research and optical imaging [1]. In all of these applications, filters have one very fundamental role, which is to pick out those signals that are of first-hand interest to the designers. Signals, here, may be speech, video, data, electrical field, voltage, current and power which carries a particular piece of information.

In this paper, it is desired to design and implement a narrow-band filter which is to be used in low-noise applications. One of such applications where it is to be used immediately is the measurement of atmospheric electric field strength by means of a ground-based equipment such as a field-mill which is an electronic sensor of atmospheric electric field. The design and implementation of the filter by frequency and impedance scaling methods are the dominant focus of this paper. The successful design and implementation of this filter will eventually lead to the design of a low-noise amplifier (LNA) to be used for the field measurement in conjunction with the field mill.

Accordingly, it is hoped that when successfully implemented, the filter will determine the operating frequency of the LNA and impart low-noise characteristics required for effective and accurate determination of the electric field strength to it.

2.0 FILTER THEORY

A filter is a frequency discriminating electrical network which passes one band of frequencies while rejecting others [9]. By so doing, it alters the amplitude and phase characteristics of a signal with respect to frequency. It changes the relative amplitudes of the various frequency components and/or their phase relationships. A filter may be passive or active. Passive filters, having no gain, are built with resistors, capacitors and opamps.

Depending on the specific purpose of a filter, it may be low-pass, high-pass, band-pass, or band-reject filter. Low-pass filters permit all signals of frequencies below a cut-off frequency, f_c to pass through them while others above that frequency are rejected.

A high-pass filter is opposite to the low-pass filter in operation. Therefore, it passes all signals of frequencies above the cut-off frequency, f_c while attenuating those below it.

A band-pass filter is that which allows the passage of signals within a band of frequencies between a lower cut-off frequency, f_{cl} and upper cut-off frequency, f_{cu} , rejecting all signals below and above these frequency limits respectively. It is always characterized by a centre frequency otherwise known as resonant frequency, f_o .

A band-stop filter, also called a notch filter, is the opposite of the band-pass filter; so it rejects a range or band of frequencies between the lower cut-off frequency, f_{cl} and upper cut-off frequency, f_{cu} . Accordingly, it passes all signal frequencies below f_{cl} and above f_{cu} respectively with a resonant frequency at which its gain is minimum.

Generally, filters are defined by their frequency-domain effects on signals, so the most useful and analytical descriptions of filters fall into the frequency domain. As a result of this, curves of gain versus frequency and phase versus frequency are commonly used to illustrate filter characteristics. A curve of gain versus frequency, also called amplitude response or frequency response is a great measure of the performance of a filter. The frequency response is a plot of voltage gain against frequency. It has three distinct regions which are the pass-band, the transition and the stop-band regions. The pass-band is the range of frequencies transmitted by a filter while the range of frequencies rejected is called the stop-band. The transition region represents the change from the pass-band to the stop-band. All filters are characterized by ideal frequency responses which have zero attenuation in the pass-band, infinite attenuation in the stop-band and vertical transitions.

These ideal characteristics are not physically realizable with practical circuits. Therefore, making the best approximations to the ideal filter performance is a necessity. Practically, standard approximations are a trade-off between various properties of the filter's transfer function (pass-band, stop-band and transition regions). The approximations may optimize the flatness of the pass-band, or the roll-off rate, or the phase shift. Well-known standard approximations are the Butterworth, Chebyshev, Bessel and elliptic approximations.

The Butterworth approximation has a maximally flat response in the pass-band which decreases gradually at the edge of the pass-band. The roll-off is smooth and monotonic, with a low-pass or high-pass roll-off rate of 20dB/decade for every pole [9]. This means that at an attenuation of 20dB, the output voltage is 0.1 of its mid-band value. The major advantage of this approximation is the flatness of the pass-band response while its disadvantage is the relatively slow roll-off rate compared with the other approximations. Roll-off is the rate at which gain value decreases.

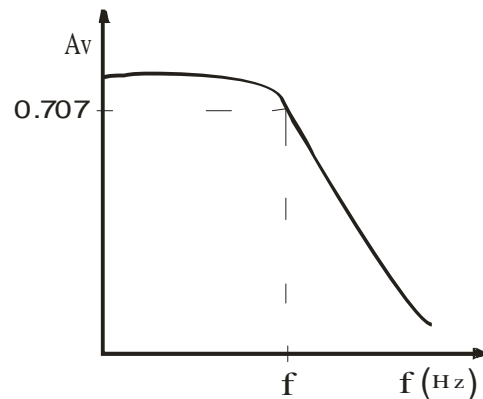

Fig. 10 : Butterworth Low-Pass Response

The Chebyshev approximation produces a steeper roll-off in the transition region than the Butterworth filter. Therefore, the attenuation with a Chebyshev filter is always greater than the attenuation of a Butterworth filter of the same order. As a disadvantage, this filter approximation is inadvertently and unavoidably associated with ripples in the pass-band [7].

The Bessel approximation has a flat pass-band and a monotonic stop-band similar to those of the Butterworth approximation. However, for the same filter order, the roll-off in the transition region is much less. This approximation will always produce the least roll-off of all approximations within the confines of defined specifications, producing a linear shift with frequency. By ensuring linear shift, it avoids distortion of non-sinusoidal signals passing through the filter. Its relative demerit is the fact that it requires the greatest circuit complexity for its implementation [9].

The elliptic filter approximation is preferable for use in applications that require the fastest possible roll-off. Its roll-off is steeper than that of a Butterworth, Chebyshev, or Bessel approximation. It optimizes the roll-off at the expense of the pass-band and stop-band which have ripples; and the phase response is extremely non-linear. Its greatest advantage is that it requires the simplest-order circuit for its implementation [7].

In this work, the Butterworth approximation is employed in the design of a multiple feedback band-pass filter which has its transfer characteristics optimized for low-noise applications.

3.0 ESSENTIAL FEATURES OF THE FILTER

In all low-noise applications, a filter circuit that passes a very narrow band of frequencies is the most suitable. For this purpose, we have chosen a band-pass filter for implementation as a first stage in a low-noise amplifier (LNA) to be used for atmospheric electric field measurement alongside a field-mill. In this section, the essential features as well as parameters of the filter are presented.

The filter is an active filter with an operational amplifier connected in the negative feedback mode as its chief active component. The operational amplifier used is the common type ($\mu 741$) which is known to have a high input impedance, low output impedance, large open-loop gain, constant voltage gain over a wide frequency range, good stability and is relatively free of drift due to ambient temperature change [12]. When connected in the inverting mode, it is operated as a negative feedback amplifier whose gain depends directly on the ratio of the feedback resistance to the input resistance; and the output signal is 180° out of phase with the input signal [4].

$$\text{Gain}(A_v) = -R_f/R_i \quad \text{---} \quad \text{---} \quad \text{---} \quad \text{---} \quad \text{---} \quad \text{---} \quad (1)$$

Negative Feedback

Feedback is a very useful tool for regulating the gain of an electronic system depending on the area of application. It may be used to increase the gain (positive feedback) as in oscillators or to decrease the gain (negative feedback) in certain amplifiers. In negative feedback, a fraction of the output signal is fed back to the input signal voltage [10]. The very attractive characteristics of negative feedback are bandwidth broadening, gain stabilization, thermal effect

reduction, noise reduction, minimization of distortion, more linear operation, raising of input impedance and lowering of output impedance. All these qualities help, in no small measure, to enhance the performance of the filter in low-noise applications. Negative feedback, no doubt, is the prime determinant of the low-noise qualities of the filter. Apart from negative feedback, other very important features of the filter are: resonant frequency, quality factor, bandwidth and noise figure.

Centre Frequency

This frequency, also known as resonant frequency, is the frequency at which the gain of the filter is maximum. The centre frequency is expressed as the geometric mean of the lower and upper cut-off frequencies, f_{cl} and f_{cu} .

$$f_0 = \sqrt{f_{cl} \cdot f_{cu}} \quad (2)$$

Quality Factor

The quality factor of a band-pass filter is a measure of the selectivity of the filter. It is the ratio of the centre frequency to the bandwidth:

$$Q = \frac{f_0}{BW} \quad (3)$$

Whenever the quality factor increases, the bandwidth becomes narrower and the filter becomes more selective. When Q is less than 1, the filter has a wideband response. In this case, the band-pass filter is usually built by cascading a low-pass stage with a high-pass stage. When Q is greater than 1, the band-pass filter has a narrow-band response, and the multiple feedback (MFB) approach is used for designing it. Specifically, the interest of the paper is in a narrow-band filter which has high sensitivity and selectivity; so the quality factor of this filter is greater than 1.

Bandwidth (BW)

The bandwidth of a filter is the frequency separation between the 3-dB upper frequency, f_{cu} and 3-dB lower frequency, f_{cl} [11]. That is:

$$BW = f_{cu} - f_{cl} \quad (4)$$

f_{cu} and f_{cl} are also called half-power points at which the voltage gain is 0.707 times the maximum gain at the centre frequency. Figure (3) shows the frequency response of the band-pass filter.

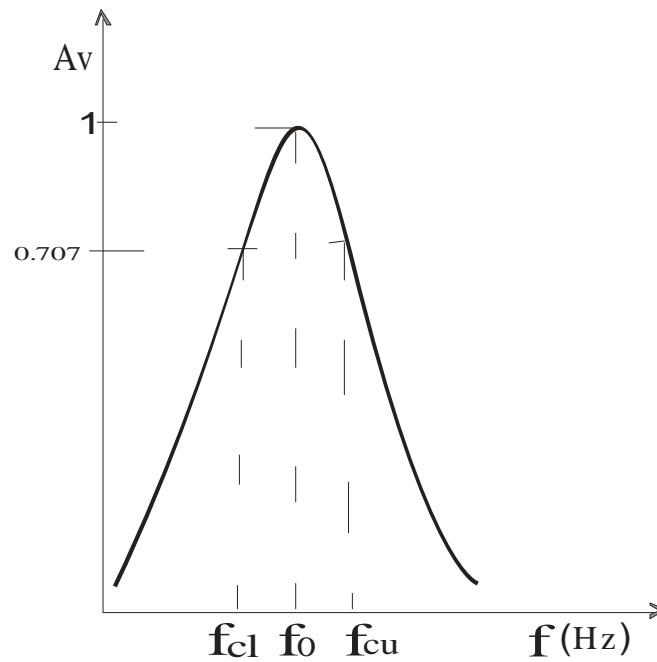

Fig. 2.0 : Frequency Response of a Bandpass Filter

Noise Figure

Noise is a spurious or random signal generated in circuits. It has very serious effects on small-signal instruments by masking the desired signal. Noise may be man-made or natural. Integrated circuits are characterized by shot noise which arises from the discrete current flow nature in electronic devices; thermal noise resulting from the chaotic motion of charge carriers; flicker noise dominant at low frequencies [8], but insignificant above 1KHz [2] and popcorn noise (burst noise) caused by imperfect semiconductor surface conditions and experienced below 100Hz [14].

To ensure optimal performance, the immunity of a circuit to noise effects must be high. A good measure of the immunity is signal-to-noise ratio otherwise known as noise figure.

Reduction of noise is greatly achieved by using filters which attenuate or suppress unwanted signals. For optimal performance, circuit parameters are adjusted to achieve minimum noise figure. In order to determine the noise level of an integrated circuit instrument, figure (4) is used.

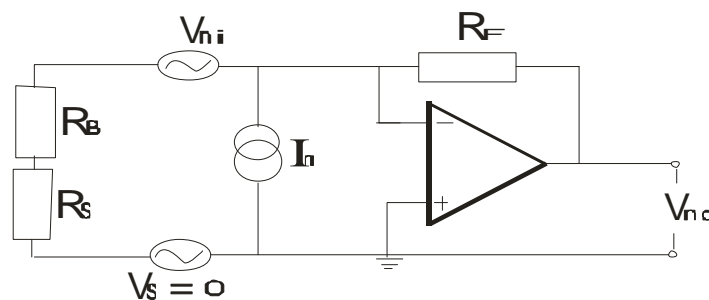

Fig. 4.0 : Circuit for Noise Measurement

$$V_{ni} = \frac{V_{no}}{A} \quad \dots \quad \dots \quad \dots \quad \dots \quad (5)$$

If $A_v = 1$, $V_{ni} = V_{no}$

Also $V_{ni} = \sqrt{BW(V_1^2 + V_2^2 + V_3^2)}$ --- --- --- (6)

Where $V_1 = V_n$

$V_2 = I_n \cdot R_x$ --- --- --- (7)

$R_x = \left[R_F^{-1} + (R_s + R_B)^{-1} \right]^{-1}$ --- --- (8)

$V_3 = \sqrt{4 \cdot K_B \cdot T_K \cdot R_x}$ --- --- --- (9)

[5]

where K_B = Boltzmann constant, T_K = Absolute temperature (273°K), V_{ni} = input noise voltage , V_{no} = output noise voltage.

On the basis of expressions (5) – (9), noise figure (F_{min}) is expressed as:

$F_{min} = \frac{\text{Signal – to–Noise ratio of input}}{\text{Signal – to–Noise ratio of output}}$

$F_{min} = \frac{\langle V_s^2 \rangle / \langle V_{ni}^2 \rangle}{A^2 \langle V_s^2 \rangle / A^2 \langle V_{ni}^2 \rangle + \langle V_{no}^2 \rangle}$ --- --- (10)

Quantitative analysis of the parameters of the filter will be carried out in section (4) which centres on design.

4.0 DESIGN PROCEDURE

The design of the filter is such that it meets certain specifications based on the desired purpose. The requirements to satisfy are that the filter be narrow-band and have the capacity to attenuate all frequencies which can distort the signal associated with the electric field at the time of measurement. One of such unwanted signals is the 50Hz background (hum) noise which is adequately taken care of in the design. With this in mind, the design is carried out so that the centre frequency of the filter corresponds to the frequency of the field to measure.

Two methods, frequency and impedance scaling, were employed in the design of the filter.

Frequency Scaling

This method, used mostly in RC filter circuits, has been used to establish the frequency of operation of the filter. This has been achieved either by varying all filter capacitance values in the same proportion or all resistance values in the same proportion. Changes in frequency are inversely related to changes in capacitance or resistance values.

Impedance Scaling

This involves changing the relative impedance levels of all filter components by a specified amount. This has helped to achieve realistic and workable element values for the circuit. The impedance scaling does not alter the frequency scale and the same thing happens when resistance values are altered to perform frequency scaling. In all, the primary purpose of impedance scaling leaves the frequency response unaltered.

Design Steps

Figure (4) gives vividly the exact picture of the filter and it is operationally equivalent to an R-L-C circuit. Its maximum gain at f_o is given as a negative function of Q since the inverting configuration of the opamp is used.

$$A_0 = -2Q^2 \quad \dots \quad \dots \quad \dots \quad (11)$$

Q has been chosen theoretically to be 4 as it was observed that this would give the desired result. All component values were computed in relation to Q.

As a first step, all capacitors were assigned a value of 1 while the resistor values were expressed as a function of Q. This is the normalization process.

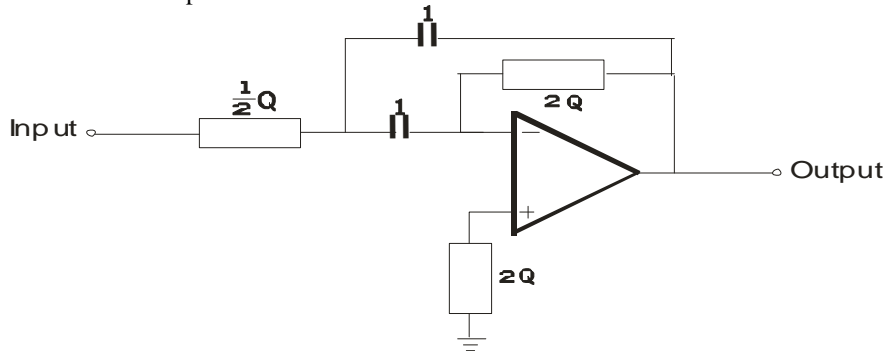

Fig. 5 : Design Circuit 1

Secondly, the frequency scaling operation was performed in such a way that the response of the normalized design was maximum at 200Hz. This led to the determination of the frequency scaling constant, K_f represented by:

$$K_f = 2\pi \times \frac{200 \text{ rad s}^{-1}}{1 \text{ rad s}^{-1}} = 1256.63706 \quad \dots \quad \dots \quad (12)$$

Each of the capacitor values was then divided by K_f to yield a number which was used for performing impedance scaling operation. That is:

$$\frac{1}{K_f} = 795.774 \times 10^{-6} \quad \dots \quad \dots \quad \dots \quad (13)$$

Each of the capacitors was then assigned this value.

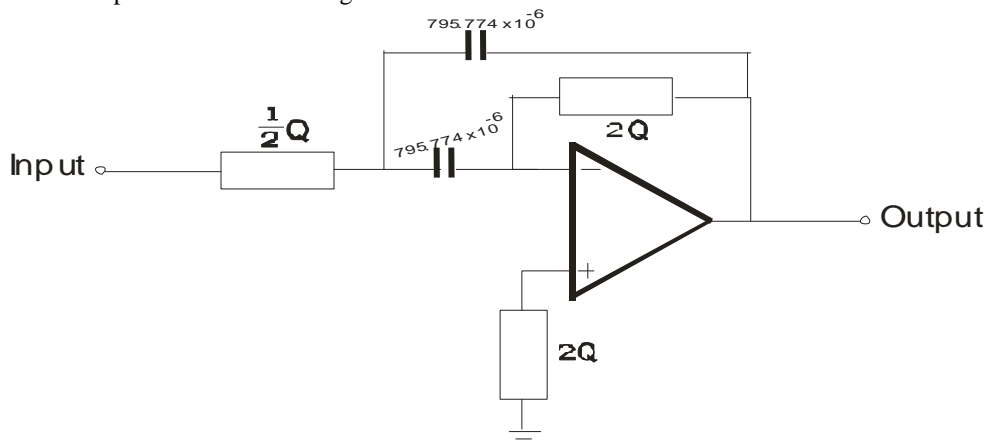

Fig. 6 : Design Circuit 2

Thirdly, the impedance scaling constant, K_i was determined such that:

$$\frac{C}{K_i} = 0.1 \times 10^{-6} \quad \dots \quad \dots \quad \dots \quad (14)$$

Therefore, $K_i = 7957.74$

The capacitor values were then changed to $0.1 \times 10^{-6} F$

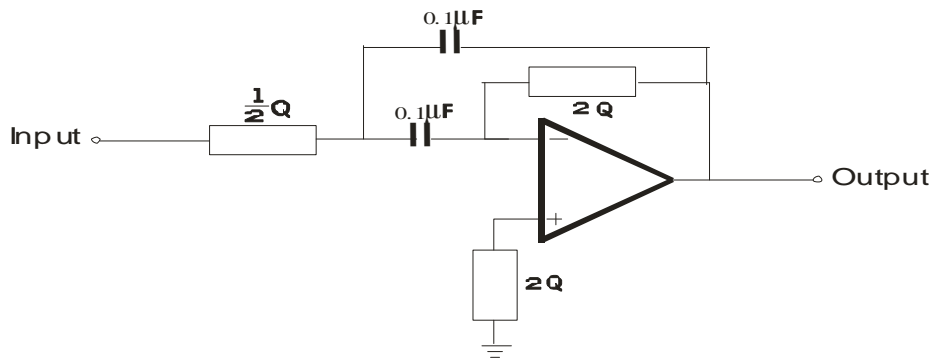

Fig. 7 : Design Circuit 3

In the fourth step, all the resistances were multiplied by K_i .

The fifth step involved the design of an attenuator network which was made to replace the $\frac{1}{2} Q K_i$ resistor. The design of this network is essential following the fact that A_o increases rapidly with the square of Q – a thing that could seriously and severely overload the opamp thereby limiting its performance. The attenuator network was placed ahead of the entire filter circuit to reduce its gain to unity. It was equally scaled by the same factor as all other resistances. It is shown in figure (8).

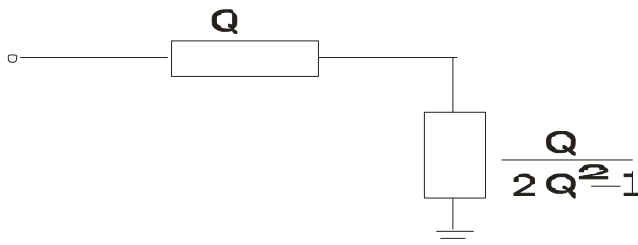

Fig. 8 : Attenuator Circuit

The sixth step was the rearrangement of the entire filter circuit for proper incorporation of the attenuator network.

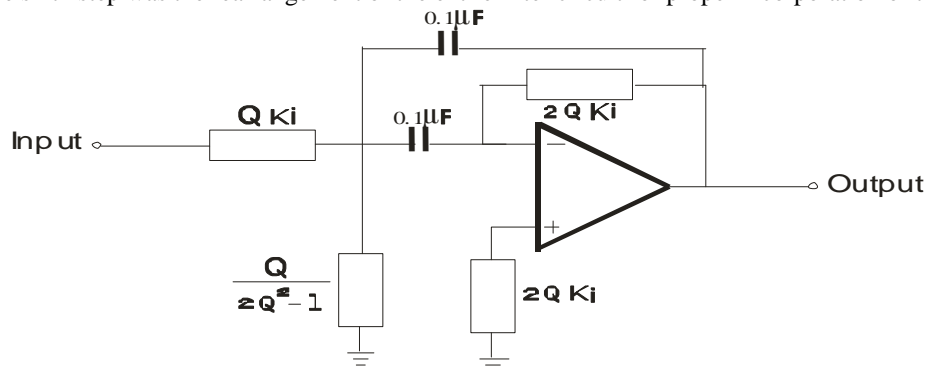

Fig. 9 : Complete Circuit with Attenuator Network

Lastly, all the resistors and capacitors were renumbered and Q changed to its original value.

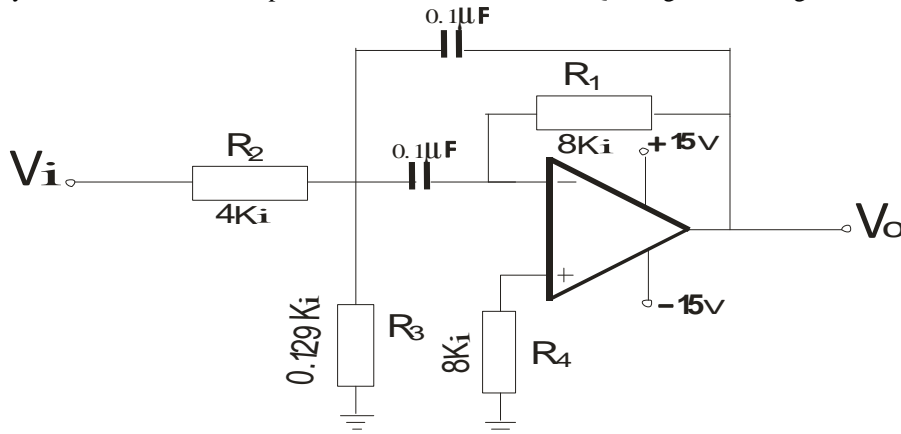

Fig. 10 : The Filter Circuit

The components of the filter designed are related to each other and other important parameters as shown in the following equations:

$$f_0 = \frac{1}{2\pi C} \left[\frac{(R_2 + R_3)}{R_3 R_2 R_1} \right]^{\frac{1}{2}} \quad [9] \quad \text{---} \quad \text{---} \quad (15)$$

$$\text{where, } R_2 = \frac{Q}{2\pi f_0 A_0 C} \quad \text{---} \quad \text{---} \quad (16)$$

$$R_3 = \frac{Q}{2\pi f_0 C (2Q^2 - A_0)} \quad \text{---} \quad \text{---} \quad (17)$$

$$R_4 = \frac{Q}{\pi f_0 C} \quad \text{---} \quad \text{---} \quad (18)$$

$$A_0 = -\frac{R_1}{2R_2} \quad [9] \quad \text{---} \quad \text{---} \quad (19)$$

When R₁ is twice as large as R₂, unity gain is established in equation (19).

Circuit analysis has shown that resistors R₂ and R₃ in the attenuator network are combined in parallel to give 1/2Q resistor in figure (7).

MATERIALS AND METHODS

The filter circuit was designed to work with a 15-V dual power supply, a signal generator and an oscilloscope for experimental procedure to determine its performance. The input from the signal generator was adjusted to 0.1V peak- to-peak at a frequency of 100Hz for a start. The signal frequency was then varied in steps of 20Hz up to 300Hz and the corresponding output voltage amplitude displayed on the oscilloscope was measured accordingly. The input voltage was kept at 0.1V throughout the experimental procedure.

The filter bandwidth was determined by measuring f_{cu} and f_{cl} when the peak- to-peak output voltage was 0.707 times the value at the centre frequency. The bandwidth obtained was 52Hz while the quality factor was 3.85Hz. All experimental results are presented in table1 followed by the frequency response of figure11.

To reduce the noise caused by thermal agitation to the barest minimum, short correcting wires were used. In the course of experimental procedure, it was observed that the output voltage was smooth and phase reversed by 180^0 as designed; the output of the filter was slightly amplified because of the presence operational amplifier in the circuit; the centre frequency obtained experimentally was the same as the theoretical value, but the quality factor obtained by experimental means was lower by only 0.1Hz.

The normalized amplitude response of the filter circuit is:

$$A_o(\text{dB}) = 10 \log \{1+Q^2(f/f_o - f_o/f)^2\} \quad \text{---} \quad \text{---} \quad \text{---} \quad \text{---} \quad (20)$$

RESULTS AND DISCUSSION

Table 1: Table of values for filter circuit

f (Hz)	V _i (V)	V _o (V)	A _v = V _o /V _i	A _v (dB) =20log V _o /V _i	f _o /f	f/f _o	A _o (dB) = 10log{1+Q ² (f/f _o -f _o /f) ² }
100.0	0.1	0.2	2.0	6.02	2.00	0.50	- 15.68
120.0	0.1	0.35	3.5	10.88	1.67	0.60	- 12.86
140.0	0.1	0.55	5.5	14.80	1.43	0.70	- 9.68
160.0	0.1	0.80	8.0	18.06	1.25	0.80	- 6.27
180.0	0.1	1.15	11.5	21.21	1.11	0.90	- 2.32
200.0	0.1	1.60	16.0	24.06	1.00	1.00	- 0.00
220.0	0.1	1.40	14.0	22.92	0.91	1.10	- 1.98
240.0	0.1	1.05	10.5	20.42	0.83	1.20	- 5.04
260.0	0.1	0.70	7.0	19.90	0.77	1.30	- 7.40
280.0	0.1	0.65	6.5	16.26	0.71	1.40	- 9.35
300.0	0.1	0.50	5.0	13.98	0.67	1.50	- 10.80

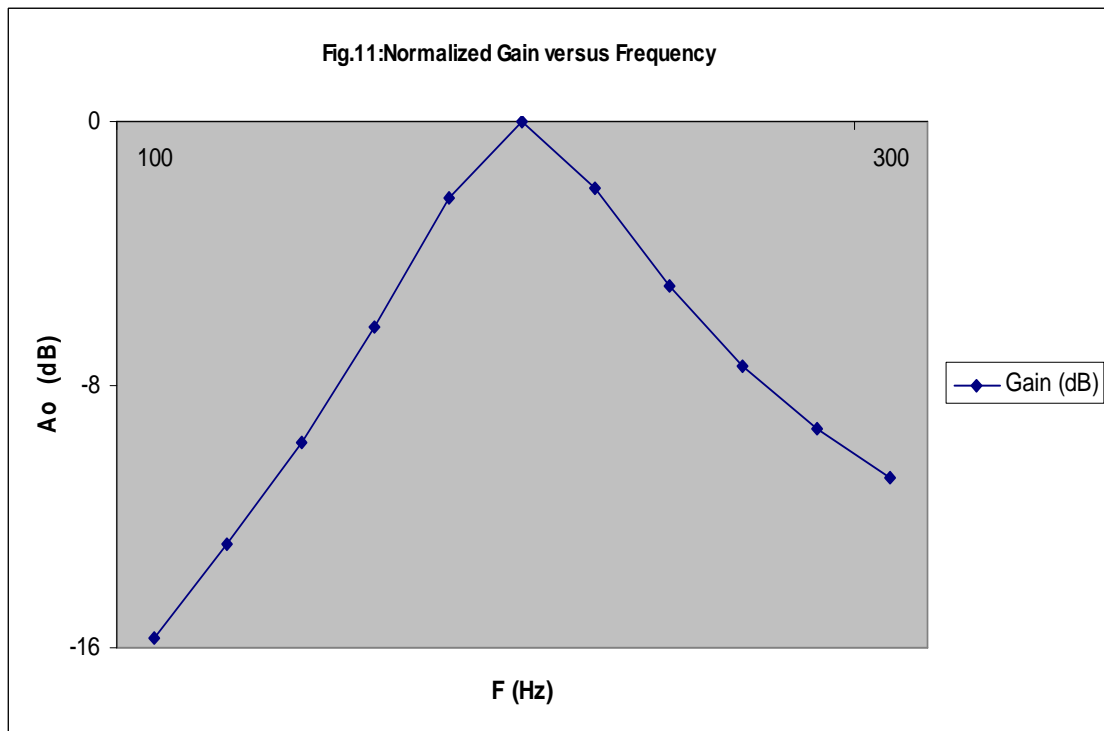

Table 2: Noise Measurements

V_{no} [V]	V_{no}^2 [V ²]	V_{ni} [mV]	V_{ni}^2 [μ V]
0.60	0.36	4.25	18.00
0.40	0.16	2.85	8.10
0.30v	0.09	2.14	4.60
0.20	0.04	1.43	2.04
$\sum V_{no} = 1.50$	$\sum V_{no}^2 = 0.65$	$\sum V_{ni} = 10.67$	$\sum V_{ni}^2 = 3.294$

Other Experimental Results.

Input voltage (V_{in})	1.60v
Output frequency (f_o)	200Hz
Centre frequency gain (A_o)	16.0
Lower 3-dB frequency (f_{cl})	176.0Hz
Upper 3-dB frequency (f_{cu})	228.0Hz
Quality factor (Q)	3.85Hz
3-dB bandwidth	52.0Hz
Mean square of signal voltage	0.01v ²
Mean square of input noise voltage	8.235μV ²
Mean square of output noise voltage	0.16V ²
Nose figure (F_{min})	2.0

In this work, a signal generator of sinusoidal waves has been used as the principal source of signals as it is done in laboratory work in electronics. This was to help determine the performance of the filter before it is taken to the field of research for actual electric field measurement in conjunction with a field mill. The design and performance test of the filter circuit have been the dominant focus of this paper. So far, the design as well as the performance level of

the filter has proven to be very successful, paving the way for the design of a low-noise amplifier (LNA) to be used for the measurement intended.

Evidence available from the experimental procedure has confirmed the frequency and impedance scaling methods employed in the design of the filter to be quite accurate.

For one, this method has been compared with equations (15) – (19), obtained from another source, for determining the components of the filter, and the agreement between the two of them is not only instructive but a greatly cherished scientific fact that this paper has come to uncover.

Another measure of accuracy of the design method is the agreement between the theoretical and experimental values of the quality factor and centre frequency. A centre frequency of 200Hz and a quality factor of 4 were theoretically chosen based on the need to meet; and all circuit components were determined based on these values. The frequency response of the filter of figure (11) shows that the experimentally determined 3-dB bandwidth of 52Hz, when put in equation (1) with a centre frequency of 200Hz gives a quality factor of 3.90, which is essentially the same as the theoretical value of 4.

Based on the design of the filter, the 50Hz background noise has been effectively removed from its operation. Experimental results show that the lower cut-off frequency (f_{cl}) of the filter is 176Hz whereas the upper cut-off frequency (f_{cu}) is 228Hz. These determine the bandwidth of the filter with the implication that signals of frequencies less than 176Hz have no passage through the filter. In addition, the impressive noise figure of (F_{min}) of 2.0, which compares favorably with noise figure of 3 [3] and 1.8 [6], shows that the filter qualifies for use in low-noise applications. The very smooth output waveform observed during performance test is another confirmatory evidence of the low-noise peculiarity of the filter.

The action of the attenuator network is visibly seen in the reduction of the gain, A_o at the centre frequency by half. Without it, the gain would be as high as 32 instead of 16 ; and this would not augur well for the entire circuit when the amplifying stage is designed and cascaded with this first stage.

CONCLUSION

The filter circuit presented herein, designed by impedance and scaling method, demonstrates the superior low-noise qualities required for the intended purpose – atmospheric electric field measurements. Its quality factor, Q of 3.9 and a bandwidth of 52Hz show clearly that it is indeed a narrow-band filter with peak performance at a centre frequency of 200Hz. Its chief noise reduction and linearity improving feature is the multiple feedback network employed in the design. It can easily be modified to satisfy low-noise requirements in other applications such as communications.

Acknowledgements

With a quantum of gratitude, we appreciate Prof. Utah E. U. of University of Uyo and the late Prof. Akande S.F.A. of Ajayi Crowder University, Ogbomosho for academic guidance and thorough editing of this work.

REFERENCES

- [1] Algarin, J. M., Lopez, M. A., Freire, M. J. and Marques, R. *New Journal of Physics*. **2011**. 13, P1- 12.
- [2] Arnaud, A. and Galup-montoro, C. *IEEE Transactions on Electron Devices*. **2003**. 50 (8), P 1815 – 1818.
- [3] Baohong, L. Jiajun, Z. and Junfa M. *Journal of Semiconductors*. **2012**. 33 (1), P 1 – 6.
- [4] Boylestad, L. R. and Nashelsky, L. *Electronic Devices and Circuit Theory*. 6 edn. Prentice-Hall Inc. New Jersey. **1996**. P 949.
- [5] Brand, J. *Handbook of Electronics: Formulas, Symbols and Definitions*. Litton Educational Publishing Inc. Van Host. **1979**. P 527.
- [6] Duster, J., Taylor, S. and Zhan, J. A 1.5dB NF, 5.8 GHz Low-Noise Amplifiers with On-Chip Matching. *IEEE Asia Solid State Circuits Conference*. **2007**.
- [7] Lacanette, K. *A Basic Introduction to Filters – Active, Passive and Switched Capacitor*. Application Note 779. National Semiconductor Americas Technical Centre. **2010**. P 22.
- [8] Lau, Y. Y., Jensen, K. L. and Levush, B. *IEEE Transactions on Plasma Science*. **2000**. 28 (3), P 794 – 797.

- [9] Malvino, A. P. *Electronic Principles. 6edn.* Tata McGraw-Hill Publishing Company Ltd. New Delhi. **2001.** P 1012.
- [10] Ochala, I., Tafon, W. S. and Moses, U. N. *International Journal of Physics.* Blackwell Educational Books. Lagos. **2010.** 1 (1), P 102 – 105.
- [11] Ochala, I. and Okeme, I. C. *Advances in Applied Science Research.* **2011.** 2 (6), P 41 – 50.
- [12] Schuler, A. C. *Electronics: Principles and Applications.* 5edn. McGraw-Hill Companies. New York. **1999.** P 454.
- [13] Scoles, G. J. *Handbook of Electronic Circuits.* Ellis Horwood Limited. Halsted. Pr. **1975.**
- [14] Stanley, W. *Operational Amplifiers with Linear Integrated Circuits.* Charles E. Merill Publishing Company. Ohio. **1984.** P 396.