

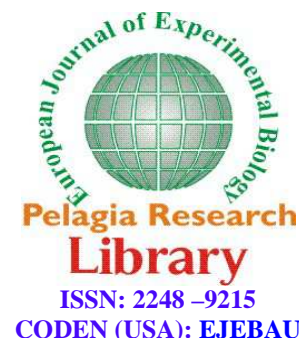

Pelagia Research Library

European Journal of Experimental Biology, 2014, 4(2):323-332



Analysis on natural fiber bone plates

D. Chandramohan

Department of Mechanical Engineering, Vel Tech, Avadi, Chennai, Tamilnadu, India

ABSTRACT

Bones are living tissue. It consists of minerals like calcium, and phosphorus. They grow rapidly during one's early years, and renew themselves. The bone is considered as a linear-elastic, isotropic, and homogeneous material. Bones are the essential part of the human skeleton. It helps to support the softer parts of the body. Trauma is a major cause of death and disability in both developed and developing countries. The World Health Organization (WHO) predicts that by the year 2020, trauma will be the leading cause of years of life lost for both developed and developing nations. The project mainly concentrates on humerus bone fracture for the case of accident due to bike riding which is most prevalent among the youngsters. The project mainly deals with the injury to the shaft of humerus broken bone must be carefully fixed in position and supported until it is strong enough to bear weight. The aim of this paper was to compare the orthopaedic alloy plates [Stainless Steel, Titanium, Cobalt chrome and Zirconium] and natural fiber [Agave sisalana fiber, Musa sapientum fiber and Hibiscus sabdariffal fiber] reinforced polymer composite bone plates used in humerus fractures. So this project mainly deals with the stress analysis of bone particularly on the humerus bone during the fixation of plate. The deflection of the bone is calculated manually and the value is compared with the ANSYS solution and the aid of rehabilitation of patients having acute pain on upper limb and vertebrae is affected by calculating the load on the spine due to plate fixation. Also this paper focuses a new method of using data obtained from CT images combined with digital CAD and rapid prototyping model for surgical planning and this new application enables the surgeon to choose the proper configuration and location of internal fixation of plate on humerus bone during orthopaedic surgery.

Keywords: Orthopaedic alloys; NFRPC; Mechanical Properties; Finite Element Analysis; CT; CAD; RPT.

INTRODUCTION

Orthopaedic surgeons have been using metallic bone plates for the fixation of humerus bone fractures. Apparently, metallic prostheses, which are generally made of stainless steel and titanium alloys, cause some problems like metal incompatibility, corrosion, magnetism effect, anode-cathode reactions, including a decrease in bone mass (osteopenia), increase in bone porosity (osteoporosis), and delay in fracture healing (callus formation, ossification) (stress shielding effect / stress protection atrophy) [12,13] Due to insufficient bone growth, refractures after the removal of the prostheses are also widely reported [13]. It was also found that the difference in the elasticity of a metallic implant and bone may cause loosening of the implant [5]. Also, in composite plates, the screw at the area of maximum bending moment was found to back out of the bone while it is rare in metal plates [12]. Thus, research on

alternative implant materials have been undertaken in the past decade. Natural fiber reinforced polymer composite materials which are less rigid than metals may be good alternatives because of properties closer to bone mechanical properties. It was found that they help to avoid stress shielding and increase bone remodeling [12]. This project aims to develop new alternative biomaterials known as biodegradable implants. We compare the efficacy of metallic bone plates and composites on the bone and fracture site.

MATERIALS AND METHODS

- The matrix material used in this investigation was bio epoxy resin Grade 3554A and Hardner 3554B. Supplied by Lab chemicals, Chennai.
- Roselle, banana and sisal fibers have been used traditionally in high strength ropes in India especially in South India regions.

2.1 Manufacturing process

1) Chemical Treatment

The fibers are powdered. Then the fibers are cleaned normally in clean running water and dried. A glass beaker is taken and 6% NaOH is added and 80% of distilled water is added and a solution is made. After adequate drying of the fibers in normal shading for 2 to 3 hours, the fibers are taken and soaked in the prepared NaOH solution. Soaking is carried out for different time intervals depending upon the strength of fiber required. In this study, the fibers are soaked in the solution for three hours. After the fibers are taken out and washed in running water, these are dried for another 2 hours. The fibers are then taken for the next fabrication process namely the Procasting process.

2) Advantages of chemical treatment

Chemical treatment with NaOH removes moisture content from the fibers thereby increasing its strength. Also, chemical treatment enhances the flexural rigidity of the fibers. Last, this treatment clears all the impurities that are adjoining the fiber material and also stabilizes the molecular orientation.

2.2 Moisture Absorption Test Procedure

Tensile, flexural and impact specimens as per ASTM standards were cut from the fabricated plate. Edges of the samples were sealed with polyester resin and subjected to moisture absorption. The composite specimens to be used for moisture absorption test were first dried in an air oven at 50 °C. Then these conditioned composite specimens were immersed in distilled water at 30 °C for about 5 days. At regular intervals, the specimens were removed from water and wiped with filter paper to remove surface water and weighed using a digital balance of 0.01mg resolution. The samples were immersed in water to permit the continuation of sorption until saturation limit was reached. The weighing was done within 30 s, in order to avoid any errors due to evaporation. The test was carried out according to ASTM D570 to find out the swelling of specimen. After 5 days, the test specimens were again taken out of the water bath and weighed.

Table 2.1 Properties of Bio-Materials

Bio-Materials	Young's Modulus (N/mm ²)	Density Kg/mm ³	Poisson ratio
[†] Humerus bone	17.2*10 ³	1.9*10 ⁻⁶	0.3
Titanium	120 *10 ³	4.51*10 ⁻⁶	0.34
Stainless steel	200	8*10 ⁻⁶	0.2
Cobalt chrome	230	8.5*10 ⁻⁶	0.3
Zirconium	200	6.1*10 ⁻⁶	0.3
^{††} Roselle and sisal (hybrid)	18857.075	1.450*10 ⁻⁶	0.33
^{††} Roselle and banana (hybrid)	22061.9593	1.5*10 ⁻⁶	0.32
^{††} Sisal and banana (hybrid)	25779.2532	1.350*10 ⁻⁶	0.30

[†]Compiled from Refs.[2,3,4,5,6,12,13]

^{††}Experimental results

2.3 Mechanical testing:

After moisture absorption tests, the tensile strength of the composites was measured with a universal testing machine in accordance with the ASTM D638 procedure at a crosshead speed of 2mm/min. Flexural tests were performed on the same machine, using the 3-point bending fixture according to ASTM D790 with the cross-head speed of 2

mm/min. In the impact test, the strength of the samples was measured using an Izod impact test machine. All test samples were notched. The procedure used for impact testing was ISO 180. The test specimen was supported as a vertical cantilever beam and broken by a single swing of a pendulum

2.4. Finite Element Analysis

Analysis package using for Stress Analysis on Humeral Shaft along with plate: ANSYS 11.0. Computerized tomography scanning image [CT scan] of humerus bone in .stl file was converted in to .iges file and then imported to ANSYS for the stress analysis on humeral shaft with plate and without plate.

Table 2.2. Element types used in the finite element model

Volume name		Element type
Bone		SOLID 92
Bone plate	Metal	SOLID 92
	Composite	SOLID 99
Screw		SOLID 92

2.5 MANUAL CALCULATION

The project case is mainly for youngsters during the bike riding. The weight of the person was assumed to be around 60 kg.

Assumption made

Initial velocity of Vehicle V_1 is 60kmph,

Final velocity of Vehicle V_2 is zero

Mass of human body=60kg

External diameter of bone $[D] = 22$ mm

Internal diameter $[d] = 11$ mm

Bending Stress on Solid Shaft:

$$\sigma_b (\max) = (32 \times M(\max)) / (3.14 \times d^3)$$

ACCELERATION

$$a = (V_2 - V_1) / \Delta t$$

Where

V_1 – initial velocity

V_2 – final velocity

Δt – change in time

Then the deceleration is 16.66m/sec²

According to Newton's Second Law:

$$\text{Force (F)} = m a$$

So, Force F= 1000N

Stress for Bone with Plate (Roselle and sisal (hybrid))

Weight of the plate:

Volume of screw= Area×thickness×No of holes on plate

$$= \pi r^2 \times t \times n$$

$$= 226.08 \text{mm}^3$$

Volume of the plate = l×w×t

$$= 150 \times 10 \times 4.5$$

$$= 6750 \text{mm}^3$$

Net volume = vol. of plate – vol. of screw

$$= 6976.08 \text{mm}^3$$

Weight of the plate per meter length = 0.000182N/mm

Table 2.3 Comparison of results Bending Stress on Solid Shaft

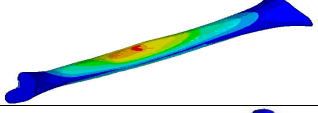
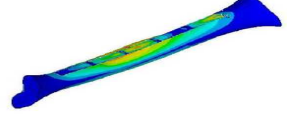
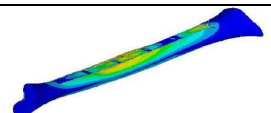
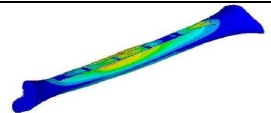
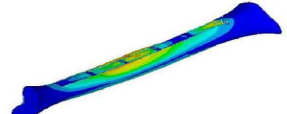
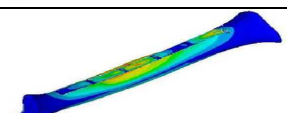
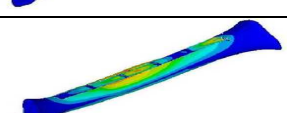
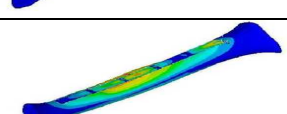
Material	Manual (N/mm ²)	ANSYS (N/mm ²)	ANSYS
Bone	64.32	74.709	
Stainless steel	65.37	74.953	
Cobalt chrome	65.46	75.124	
Titanium	65.56	75.221	
Zirconium	65.48	74.973	
Roselle and sisal (hybrid)	65.032	73.111	
Sisal and banana (hybrid)	65.010	73.233	
Roselle and banana (hybrid)	65.014	73.523	

RESULTS AND DISCUSSION

3.1 CLAPEYRON'S THEOREM OF THREE MOMENTS

It states, "If a beam has n supports, the end ones being fixed, then the same number of equations required to determine the support moment may be obtained from the consecutive pairs of spans i.e., AB – BC – CD and so on. The transfer of forces from shoulder joint in to spine in abducted upper limb using the theorem of three moments.

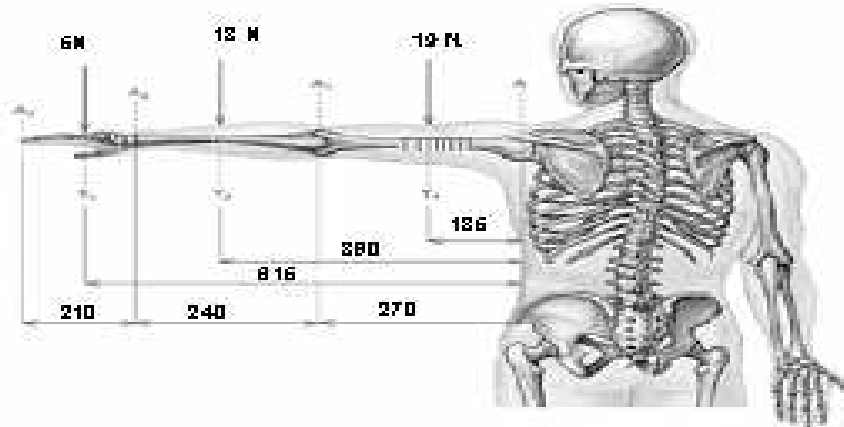

(All dimensions are in mm)

Fig 3.1 Biomechanical model of abducted upper limb

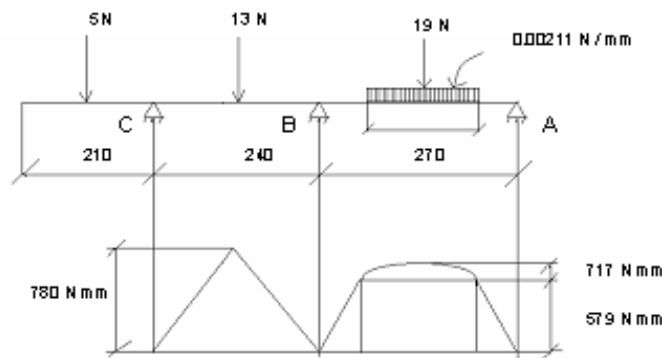

Fig 3.2 Abducted upper limb is simplified in to continuous beam with 'n' supports

THREE MOMENT EQUATION

$$M_A * L_1 + 2 * M_B (L_1+L_2) + M_C * L_2 + (6 * A_1 * x_1) / L_1 + (6 * A_2 * x_2) / L_2$$

$$M_A = 0$$

$$M_c = 5 * 105$$

$$= 525 \text{ N mm}$$

Area for span BC (A2)

$$F_2 / 2 = 13 / 2$$

$$= 6.5 \text{ N}$$

$$=6.5 * 120 =780 \text{ N mm}$$

$$\text{Area} = \frac{1}{2} * b * h$$

$$= \frac{1}{2} * 240 * 780$$

$$=93600 \text{ N mm}^2$$

Area for span AB (A1)

$$F1/2 = 19.3/2$$

$$=9.6 \text{ N}$$

Bending moment before UDL

$$= 579.49 \text{ N mm}$$

Bending moment at mid of UDL

$$= 1297.29 \text{ N mm}$$

$$A1 = 2 * \frac{1}{2} * 579.49 * 60 + 579.49 * 150 + \frac{2}{3} (1297 - 579.49)$$

$$= 122171.85 \text{ N mm}^2$$

$$MA * L1 + 2 * MB (L1+L2) + MC * L2 + (6 * A1 * x1) / L1 + (6 * A2 * x2) / L2$$

$$MB = -758.15 \text{ N mm}$$

$$RA * 270 = 19 * 135 + 0.00211 * 150 * (75 + 60) - 758.15$$

$$= 6.96 \text{ N}$$

$$RC * 240 = 13 * 120 - 758.15$$

$$= 3.4 \text{ N}$$

$$RB = 26.94 \text{ N}$$

MAXIMUM BENDING MOMENT AT THE MID-SHAFT

$$M (\text{max}) = (26.94 * 135)$$

$$= 3636.9 \text{ N-mm}$$

SOLID SHAFT (HUMERUS BONE) SUBJECTED TO BENDING

$$\sigma_b (\text{max}) = (32 * M (\text{max})) / (3.14 * d^3)$$

$$= 7.7 \text{ N/mm}^2$$

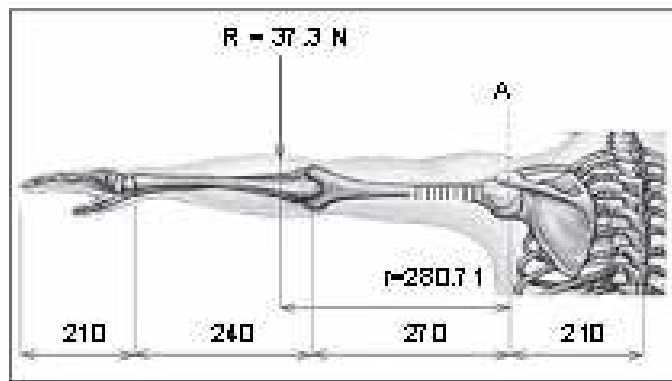

**Fig 3.3 The resultant force (R) and position (r) of individual forces applied in the relation to the shoulder joint
Resultant force(R)=F1+F2+F3+WEIGHT OF PLATE**

Resultant force (R) =37.3 N

$$R * r = (F1 + \text{weight of plate}) * r1 + F2 * r2 + F3 * r3$$

$$= (19 + .0033*150) * 135 + 13*390 + 5*615$$

$$r = 280.71 \text{ mm}$$

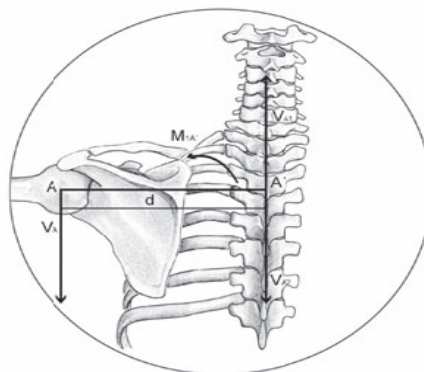

Fig 3.4 The transfer of forces from shoulder joint in to spine in abducted upper limb

$$\sum V = 0 \quad \text{Sum of vertical forces in the plane is zero}$$

$$VA - R = 0$$

$$VA = R = 37.3 \text{ N}$$

For the vertical forces VA two equally strong forces VA1 & VA2 are considered in the spine (balanced system forces). These two forces have a common application point A; they are of the same magnitude but opposite sense. The forces VA and VA1 generate positive bending moment of force on the moment arm d. $M1 A = VA * d = 37.3 * 210 = 7833 \text{ N mm}$.

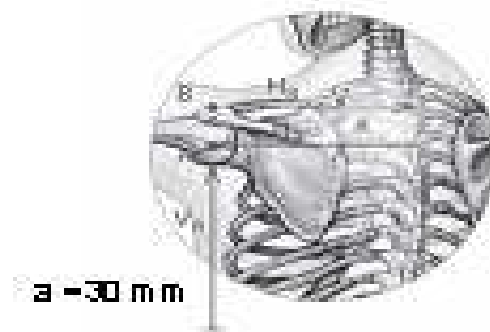

Fig 3.5 The effect of an abducted upper limb on the shoulder joint

$\sum M_A = 0$. Sum of moment of forces applied to the point A equals zero.

$$-H_B * a + R * r = 0$$

$$H_B = R * r / a$$

$$= 37.3 * 280.71 / 30$$

$$H_B = 349.0161 \text{ N}$$

The horizontal force H_B generates in relation to the point A on moment arm 'a'.

$$\text{Force moment } M_2 A = H_B * a$$

$$= 349.0161 * 30$$

$$= 10470.483 \text{ N mm.}$$

$\sum M_B = 0$. Sum of moment of forces applied to the point B equals zero.

$$-H_A * a + R * r = 0$$

$$H_A = R * r / a$$

$$= 37.3 * 280.71 / 30$$

$$H_A = 349.0161 \text{ N}$$

The horizontal force H_A generates in relation to the point A on moment arm 'a'.

During abduction of upper limb Spine is stressed by

Resulting moment of forces (M) applied upon the spine

$$M = M_1 A + M_2 A$$

$$= 7833 + 10470.483$$

$$= 18303.483 \text{ N mm}$$

Compressive vertical force ($V_A 2$) = - 37.3 N

Bending moment (max) = $RB * (L1 + d)$

= $(26.94 * 480)$

= 12931.2 N mm

3.2 REHABILITATION AID FOR PATIENTS

3.2.1 Rehabilitation

Humeral shaft fractures heal in about three months. During the first three to four weeks, you may feel the fracture fragments shift as you move your arm. This is normal for fractures that have not been treated with surgery. Your shoulder and elbow may become somewhat stiff because you will not be using the joints normally. Physical therapy is usually recommended to regain both strength and range of motion in the shoulder and elbow. Rehabilitation will begin once your surgeon feels that the fracture is stable enough to begin regaining the range of motion in your shoulder and elbow. If surgery has been required, the rehabilitation program will be modified to protect the fixation of the fracture fragments. Your surgeon will communicate with your physical therapist to make sure that your rehabilitation program does not risk causing the fixation to fail. If the surgeon feels that the fixation is very solid, you may be able progress your program quickly; if the fixation is not so solid, the speed at which you progress may need to be slowed until more healing occurs. The prognosis for humeral shaft fractures is generally excellent. The humeral shaft is covered by thick muscles. The shoulder has the largest range of motion of any joint in the body. What this means is that even if the fracture fragments do not heal exactly in their normal position the shoulder joint can easily compensate and provide you with a well functioning arm and the bulk of the arm generally hides any residual angulation in the humerus.

3.2.2 SETTING UP METHODOLOGY OF MOTORIC THERAPY FOCUSED ON EXERCISING UPPER LIMBS IN OSTEOPOROTIC PATIENTS

- ✓ Exclude from Dynamic strengthening of UL with rubber band.
- ✓ Dumbbell exercises are not suitable because there is an increase of vertical compressive force upon the mechanically weakened spine in the magnitude of the sum of masses of both dumbbells.
- ✓ In exercises there is an increase of the magnitude of bending moment of force applied to humerus bone and spine.
- ✓ The bending moment and vertical compressive force are increases by the abduction of weight of the dumbbells.
- ✓ Strengthening of upper limb with dumbbell and lifting of weight by one upper limb represent the most unfavorable load of spine in upper limb motoric activity.

3.2.3 APPLICATION OF BASIC PRINCIPLES OF MOTORIC ACTIVITY IN DAILY ROUTINE:

- ✓ To avoid carrying and lifting heavy weights ,
- ✓ Always to carry and lift weights with both hands,
- ✓ When shopping ,always use shopping trolleys.
- ✓ Don't carry shopping bags in one hand,
- ✓ Should always sit down in public transport, when they stand and hold themselves by one hand, the impact force in case sudden braking is unfavorably transferred to spine,
- ✓ To exclude sports straining (tennis , hand ball , volley ball ,etc.,)

3.2.4 BENEFITS OF PROPOSED AID

- ✓ Using the proposed aid would lower costs of medicamentous therapy in acute fracture stage.
- ✓ Gradual adoption of the humeral musculature in the stage of acute fracture the proposed rehabilitation aid focused at strengthening UL.
- ✓ Lowering cost of long time medicamentous therapy of chronic pain.

CONCLUSION

The stress analysis of humerus bone and fixation of plate for the fractured bone has been carried out with stainless steel, cobalt chrome, titanium, zirconium, Roselle and sisal (hybrid), Sisal and banana (hybrid) and Roselle and banana (hybrid). After plate fixation, the stress induced on the bone with plate and without plate is calculated both manually and using ANSYS software. Although titanium alloy has high strength, when compared to other materials (results shown in table 3.2), the problems associated with its use include: metal incompatibility, corrosion, magnetism effect, anode-cathode reactions, decrease in bone mass (osteopenia), increase in bone porosity

(osteoporosis), and delay in fracture healing (callus formation, ossification). During adduction and abduction of upper limb spine is stressed by Resultant moment of forces (M) = 18303.483 N mm compressive vertical force (VA 2) = - 37.3 N Bending moment (max) = 12931.2 N mm. Thus, with the development of biocomposite materials, an increase in bone density is promoted due to a more suitable environment for bone growth due to the high resistance to corrosion of biopolymers and natural fibers. Fracture healing can be faster with the Natural Fiber Reinforced Polymer Composite bone plates. So this research muscularly gives confidence to utilize the advantages offered by renewable resources and its application in the field of orthopedics for bone graft substitutes.

REFERENCES

- [1] Abrao, A.M., P.E. Faria, J.C. Campos Rubio, P. Reis and J.P. Davim, **2006**. *J. Materials Process. Technol.*, 186: 1-7. DOI: 10.1016/j.jmatprotec.2006.11.146.
- [2] Baixauli, **1995**. *J. Bone Joint Surg.*, 77: 227-227.
- [3] Boeree, N.R., J. Dove, J.J. Copper, J. Knowles and G.W. Hastings, **1993**. *Biomaterials*, 14: 793-796. DOI: 10.1016/0142-9612(93)90046-5.
- [4] Chandramohan, D. and J.Bharanichandar, **2013**. *Proc. American J .Env. Sci.*, 9 : 494-504. DOI:10.3844/ajessp.2013.494.504.
- [5] Chandramohan, D. and K. Marimuthu, **2011**. *Proc. Int. J. Materials Sci.*, 5: 445-463.
- [6] Chandramohan, D., K. Marimuthu, S. Rajesh and M. Ravikumar, **2010**. *Proceedings of Malaysian. J. Educational Technol.*, 10: 73-81.
- [7] Clemons, C.M. and D.F. Caulfield, **1994**. *Natural fibers Sage. J. Reinforced Plastics Composites*. pp: 1354-66.
- [8] Charvet, J.L., **2000**. *J. Mater. Sci. Materials Med.*, 11: 101-109. DOI: 10.1023/A:1008945017668.
- [9] Fenner, R., **1996**. High strength partially absorbable composites produced by sintering method for internal bone fixation. *Proceedings of the Transaction of 5th World Biomaterials Congress, (BC' 96)*, Toronto, Canada, pp: 440-440.
- [10] Ganesh, V., **2005**. *BioMed. Eng. OnLine*, 4: 46-46. DOI: 10.1186/1475-925X-4-46
- [11] Joseph, K., R. Dias, T. Filho, B. James and S. Thomas *et al.*, **1999**. *Composites Revista Brasileira de Engenharia Agrícola e Ambiental*, 3: 367-379.
- [12] Navarro, M., **2008**. Biomaterials in orthopaedics. *J. Royal Soc. Interface*, 5: 1137-1137. DOI: 10.1098/rsif.2008.0151.
- [13] Ramakrishna, K., **2004**. Design of fracture fixation plate for necessary and sufficient bone stress shielding. *JSME Int. J., Series C: Mechanical Syst. Machine Elements Manuf.*, 47: 1086-1094. DOI: 10.1299/jsmec.47.1086.